



# ANATOMY OF AN AUTOMOBILE continued...





# Propulsion System

- Conventional
  - ◆ This is your internal Combustion Engine (Gas and/or Diesel)
- CNG (Also, Propane, Butane, LNG)
  - ◆ Powered by compressed Natural Gas
- Electric
  - ◆ Electric battery powered vehicles
- Hybrid
  - ◆ Electric low speed and gas high speed



# Propulsion System

- Conventional
  - ◆ Majority of vehicles on the road
  - ◆ Use internal combustion engines
  - ◆ Burn gasoline or diesel fuel
    - ◆ Hazards
      - Fuel leaks
      - Short circuits
      - Battery acid leaks





# Propulsion System

- CNG (Also, Propane, Butane, LNG)
  - ◆ Powered by compressed natural gas (CNG)
    - ◆ Cylinders usually in trunk, but can be in any convenient location
    - ◆ City buses and other fleet vehicles
    - ◆ Identified by CNG sticker mounted on front and back of vehicle



# Propulsion System

## ■ CNG

- ◆ After crash, cylinders or fuel lines could be damaged.
  - ◆ CNG could escape.
  - ◆ Threat of BLEVE





# Propulsion System

## ■ Electric

- ◆ On November 14, 1996, General Motors Corporation rolled its' first **all-electric** vehicle off the assembly line
- ◆ Named the **EV1**, this two-passenger coupe is available through its **Saturn** dealerships in California and Arizona



# Propulsion System

- Electric
  - ◆ Propelled by electric motor powered by batteries
  - ◆ Contains a large number of batteries
  - ◆ Hazards
    - ◆ Large amount of energy stored in batteries
    - ◆ Potential electrical shorts
    - ◆ Leakage from damaged batteries
    - ◆ Voltage higher than 12-volt car battery



# Propulsion System

- Electric

EV1 is powered by a large bank of **26 12-volt lead-acid batteries**

Car can travel a distance of **90 miles** before its batteries need recharging

A wall-mounted charger and plug are used to hook into the front of the vehicle for recharging the battery bank



# Propulsion System

- Electric

**Verdugo Fire Academy**

**Ch.25**

... more than fighting fires





# Propulsion System

- Hybrid
  - ◆ Use high voltage battery-powered electric motors (144 to 600 volts) and a gasoline-powered engine with a 12 volt electrical system
  - ◆ Electric power used at low speed, gas power at high speed
  - ◆ When stopped at a traffic light, both sources of power turn off. Sleep mode. **(WARNING)**
    - ◆ Car said to be hibernating

# Propulsion System

- Hybrid
  - ◆ Hazards posed are same as gas and electric-powered vehicles.





# Propulsion System

## ■ Hybrid

**Toyota  
Prius**



**Honda  
Civic  
Hybrid**

**Honda  
Insight**



**Others makers:  
Chevrolet  
GMC  
Mercury  
Dodge  
Porsche  
Ford  
Lexus  
Saturn**

# Propulsion System

- Hybrid Things to Know:
  - ◆ Electrical system wiring is bright Orange
  - ◆ Chalk Tires until electrical and gas system is disconnected, car in sleep mode!!!





**Verdugo Fire Academy**

... more than fighting fires

**Ch.25**

# Video

0850 to 0985  
Holmatro 4



# Frame Design

There are three basic trends in the framework of today's automobiles:

- Unit-body
- Full-frame
- Space-frame designs.

Each design has unique qualities, and each type of vehicle should be studied.



## Frame design

# Unit-Body design

- Most prevalent technique used today.
- The design has no frame underneath the body to hold the components together... instead, it uses the floor, posts, doors, and roof to hold the car together.

## Frame design Unit-Body design

- Most prevalent technique used today.
- The design has no frame underneath the body.





# Frame design Unit-Body design

- Another look...



# Frame design

## Unit-Body design

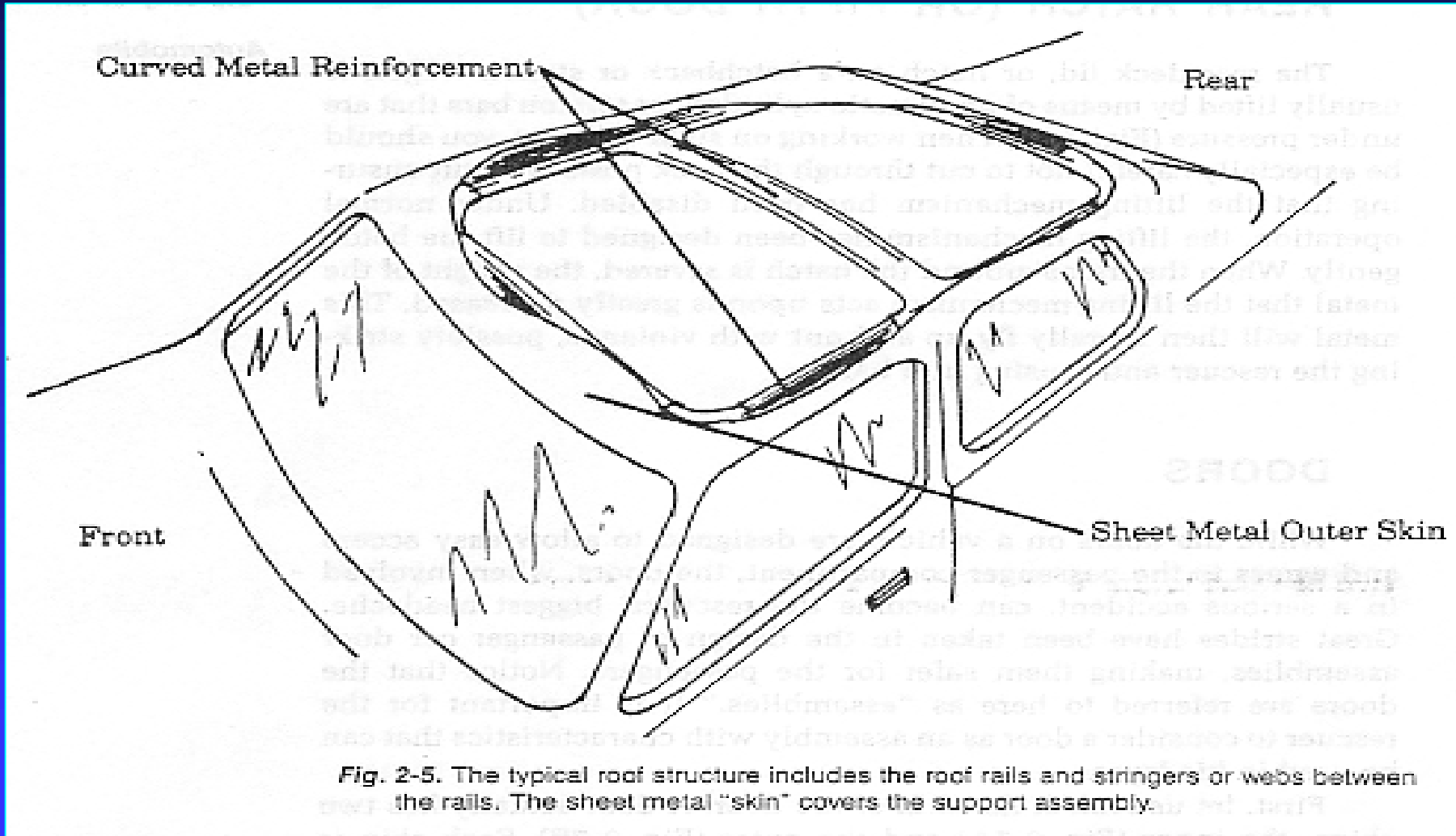

Fig. 2-5. The typical roof structure includes the roof rails and stringers or webs between the rails. The sheet metal "skin" covers the support assembly.



# Frame design

## Unit-Body design

In 2003, Volvo's SUV, the XC-90, was an industry first adding a rollover protections system with a BORON steel reinforced roof structure (high strength, low alloy metal).





## Frame design Unit-Body design

- Similar to roof truss building construction where construction members are under tension and/or compression, the vehicle is structurally sound.
- Because of the construction, completely stabilize and crib the vehicle prior to taking any actions such as cutting roof posts.
- Why?



## Frame design

# Full-Frame design

- Full-frame type design is found mostly on station wagons and light trucks.
- Full-frame has two steel rails providing the support to which the floor, suspension, drive train, and body are attached.
- While a full frame gives the vehicle good support, it is still essential to stabilize all vehicles properly prior to performing rescue techniques.



# Frame design

## Full-Frame design

**Verdugo Fire Academy**

**Ch.25**

... more than fighting fires





Frame design

**Sub-Frame design** Similar to full with only part of the frame showing...

**Verdugo Fire Academy**

**Ch.25**

... more than fighting fires





## Frame design Space-Frame design

Introduced to the nation in the 1983 Pontiac Fiero.

- This design trend has been well received by the auto industry, and we can expect to see more use of it in the future.
- Space frame resembles a bird cage, the frame is self-supporting, and the body consists of a series of plastic panels attached to a space frame with rivets and screws.



## Frame design

# Space-Frame design

- The body is designed for appearance and to protect the passengers from the elements, not for support of the structure.
- Therefore, it may be necessary for rescuers to remove the body panels in order to get to the metal that is actually entrapping the patient.
- Most older model space-frame materials are steel but all-plastic models have been successfully crash tested.

# Frame design Space-Frame design

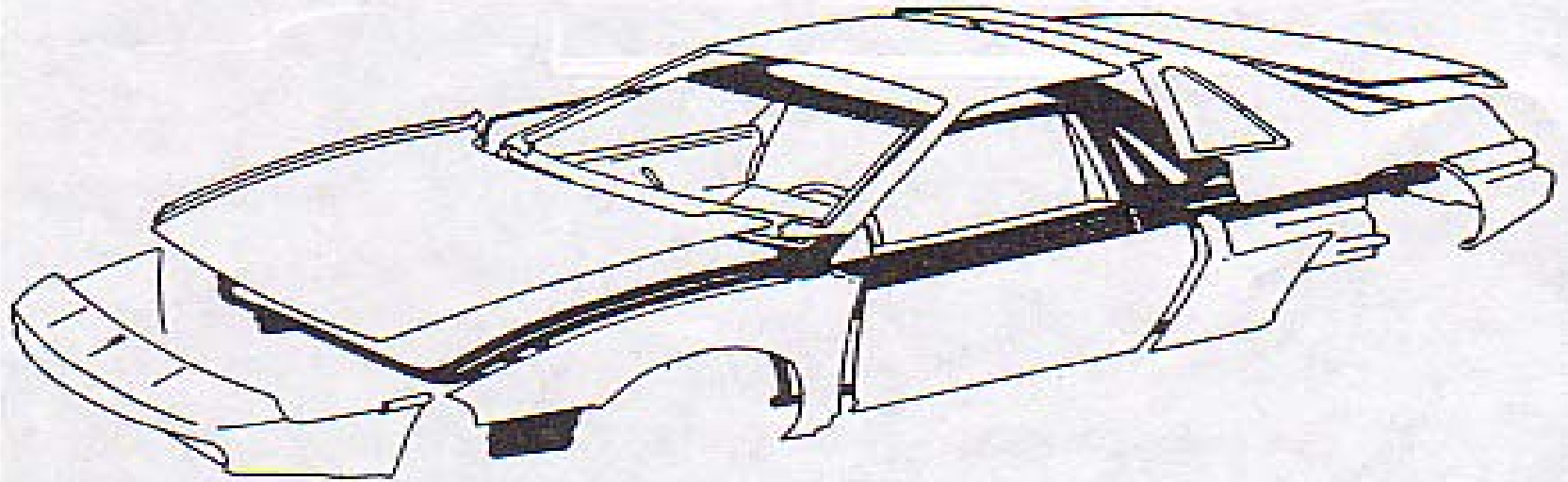

Fig. 2-3. A relatively new design trend, the space frame resembles a bird cage onto which the body panels are attached with fasteners and adhesives.



# PLASTICS in Auto's

- In 1986, the United States, for the first time ever, produced more pounds of plastic than steel, largely attributed to the automobile industry.
- Plastics and polymers now replace the heavier steel in many applications. The reason is the all mighty dollar: plastic is cheaper than steel.



# Plastics

**How does all this affect the rescuer?**

- First, plastic burns well, produces harmful and even deadly, gases and heavy black smoke.
- As far as extrication is concerned, plastic panels inside the car can be penetrated by extremities (most often the knees) and trap the patient like a pair of “Chinese handcuffs.”
- This problem presents a challenge to the rescuer, who must cut away the plastic.

# THE VEHICLE

- When discussing vehicle anatomy, we will break the car into two basic categories:
- Exterior parts of a car  
*and*
- Interior parts of a car

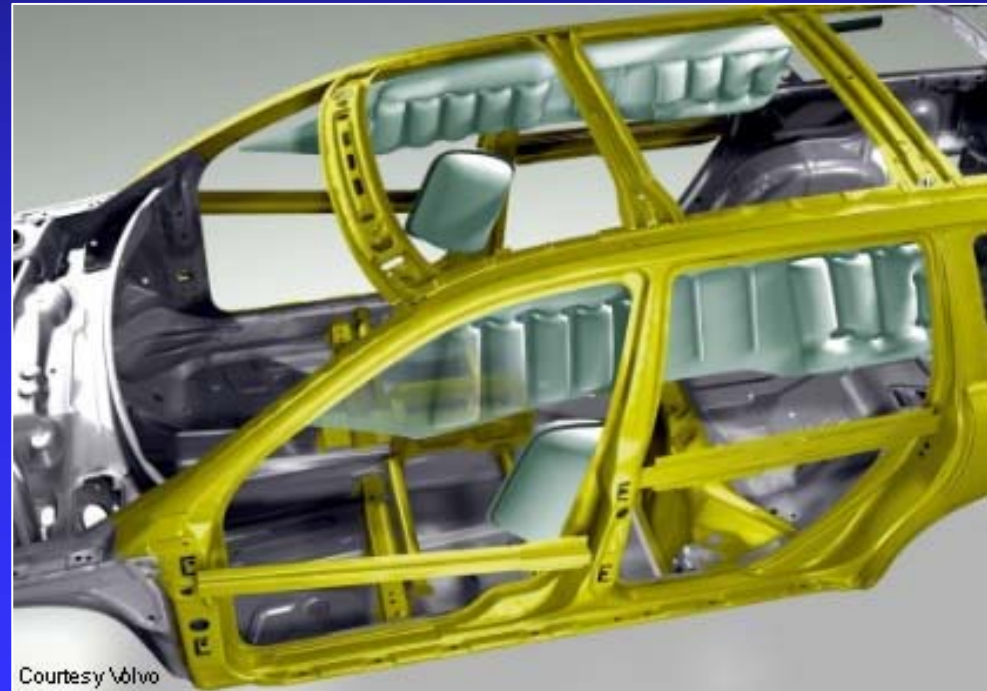



# Exterior Parts

## PILLARS

- Posts add structural integrity to the vehicle.
- Support the dash assembly (A post/pillar).
- Support seat-belt retractor assemblies.
- Serve as part of a window frame.
- In some cases serve as wiring chase.
- **They are primary targets for the rescuer who desires to remove the roof.**



## Exterior Parts

# PILLARS

- Post are usually made of rolled sheet metal and are hollow.
- Usually reinforced at each end.
- Are of a shingle thickness of metal at the center making the center of the pillar the weakest point.
- Exceptions to this “rule” include the B-pillar that house steel reinforcing plates for seat belts and the rear pillar of most sedans.



## Exterior Parts

# PILLARS

When looking at a post, try to imagine that the pillar is a column that extends from the floor level to the roof rail. It is then easier to understand why a car folds around a patient as is does; this columnar concept makes it easier for you to solve the problems of disentanglement.



# Exterior Parts

# PILLARS

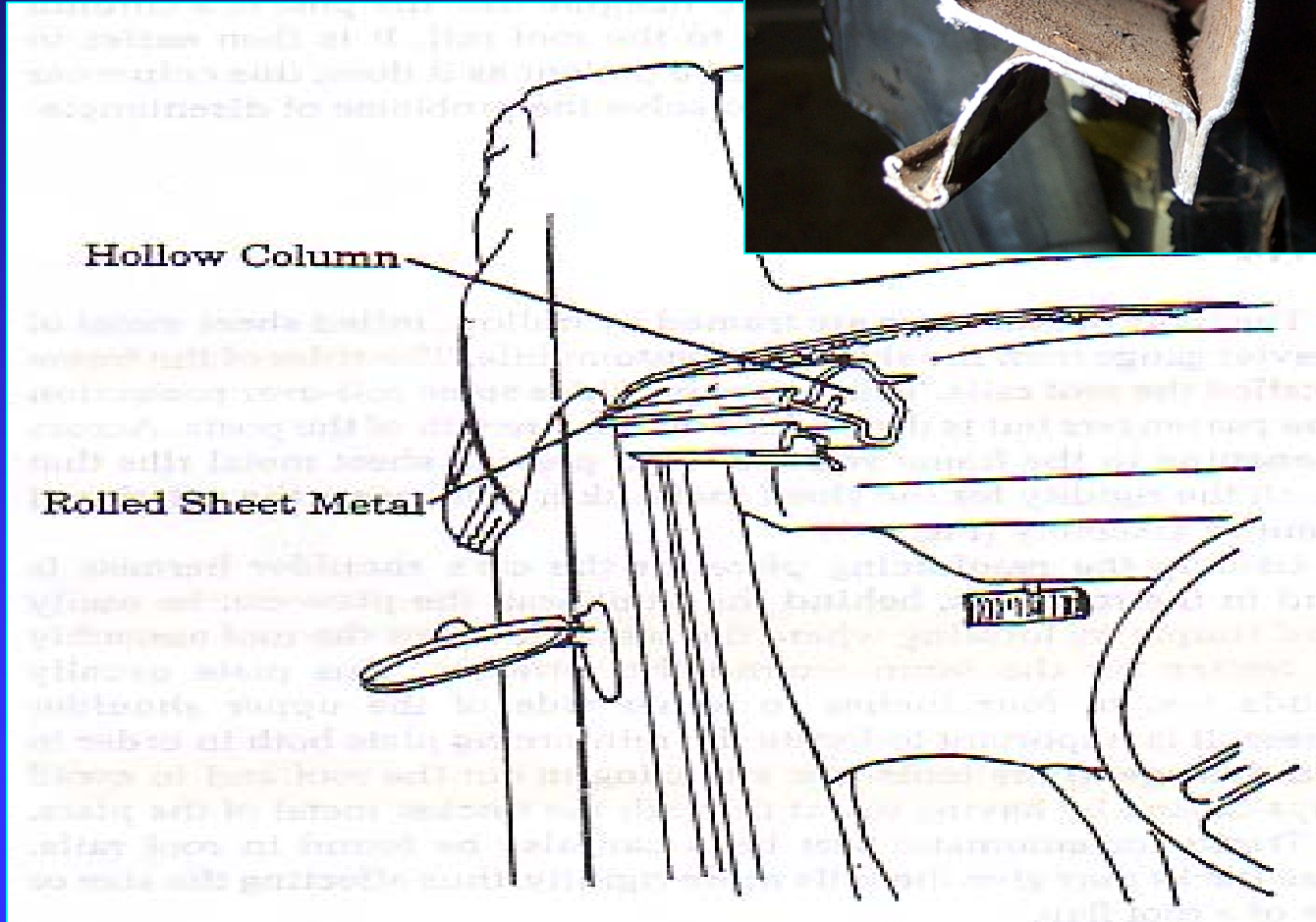

## Exterior Parts

# ROOF

- The roofs of most cars are framed by hollow, rolled sheet metal of a heavier gauge than the skin of the automobile.

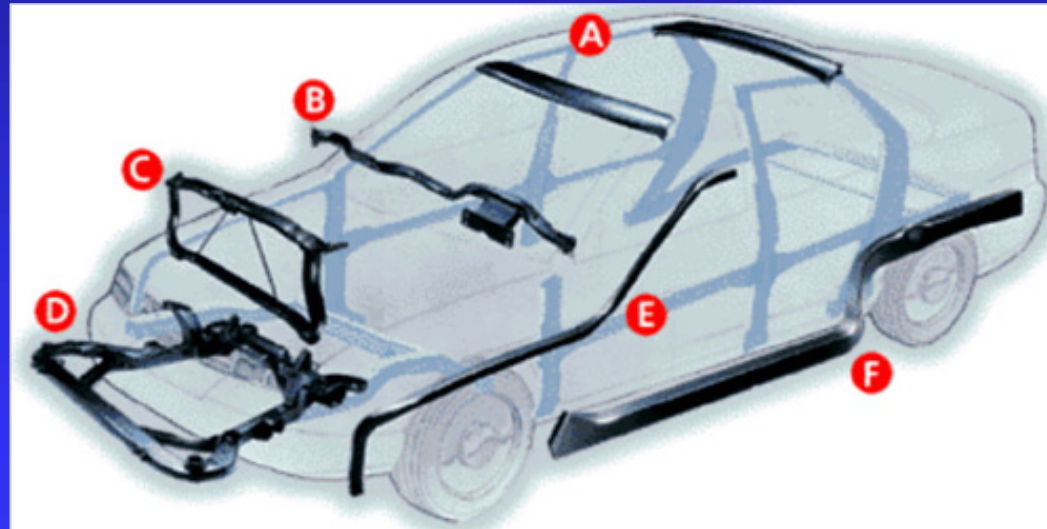

## Exterior Parts

# ROOF

- This frame provides some roll-over protection but is dependent on the strength of the posts.
- Across the opening in the frame you will find pressed sheet metal ribs to furnish rigidity for the sheet metal skin cover.





## Exterior Parts

# ROOF

- Reinforcement plates for the seat belts can be located where the seat belt enters the roof assembly and feeling for the lump around the retractor.
- **Warning:** To avoid damage to the tools you are using to cut the roof and to avoid delays caused by having to cut through the thicker metal of the plate, cut the roof rails.



## Exterior Parts

# Doors

- While the doors on a vehicle are designed to allow easy access and egress to the passenger compartment, the doors, when involved in a serious accident, can become the rescuers' biggest headache.
- It is important for the rescuer to consider a door as an assembly with characteristics that can be used in his favor.

## Exterior Parts Doors

- First, inside the door is a side-guard beam that extends from the area around the latch to the front side of the door, somewhere at the pillar.



## Exterior Parts Doors

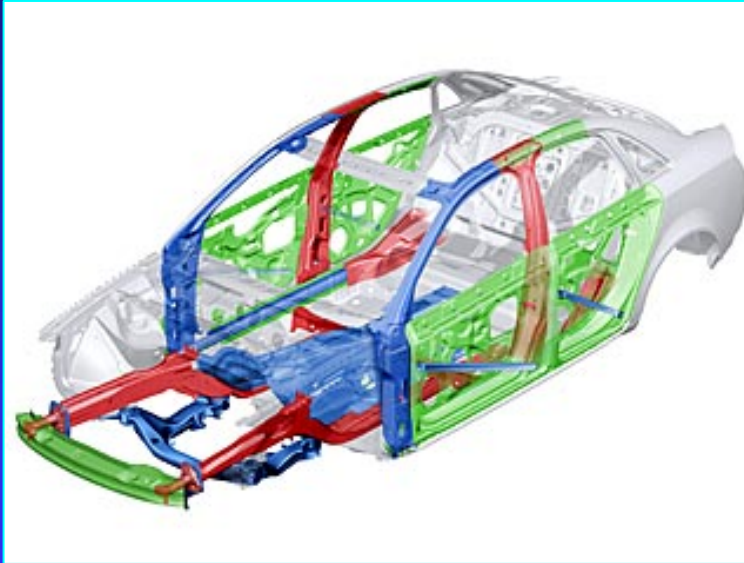

- The bars are made of heavy-gauge sheet metal, next generation models are made of boron or titanium having a tensile strength far above many tools ability to cut.

## Exterior Parts Doors

- Note the integrity of the door remains intact.

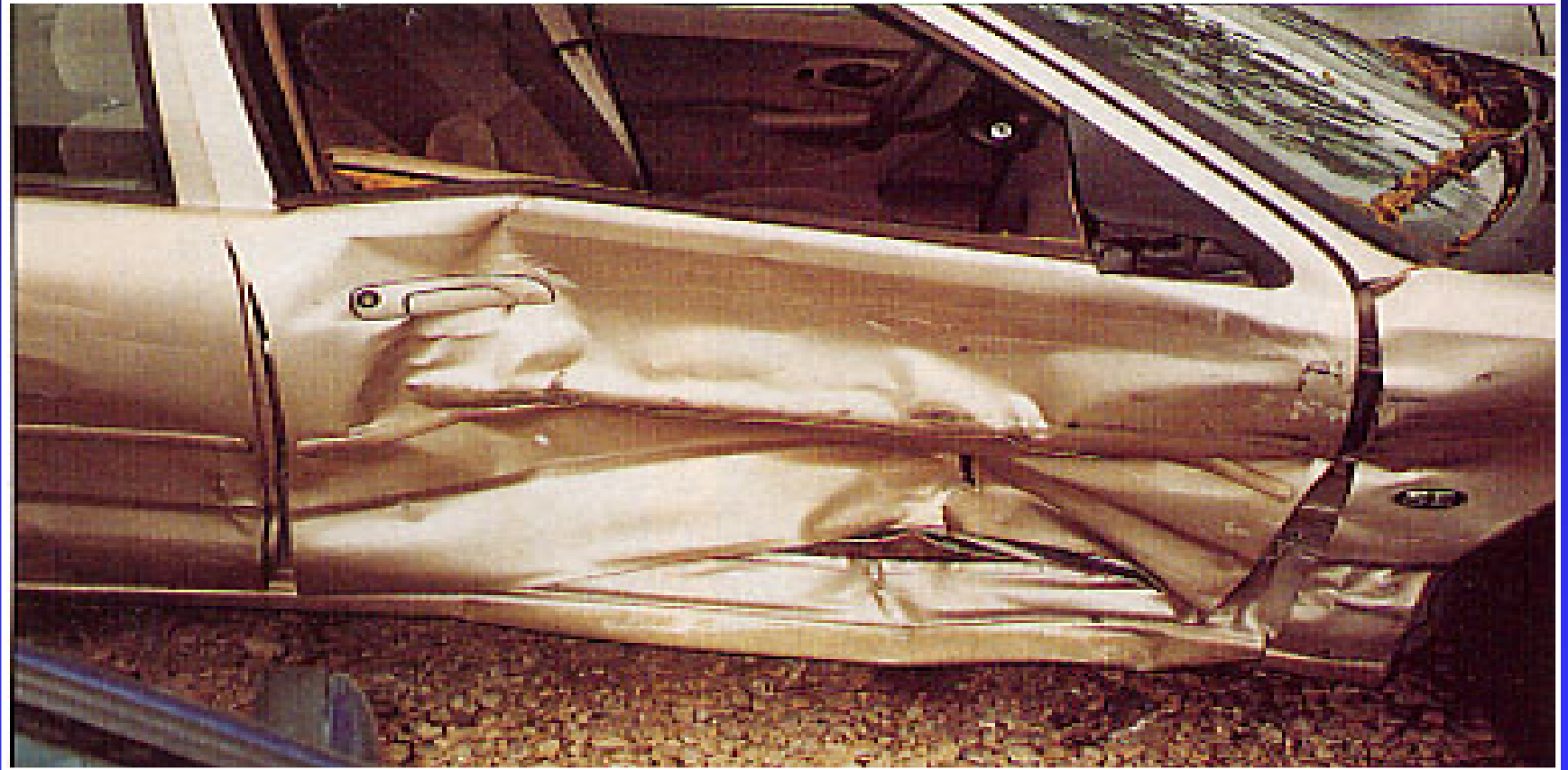

## Exterior Parts

# Doors

- Other configurations to consider.
- Note: The door latch is seated into the side guards design.

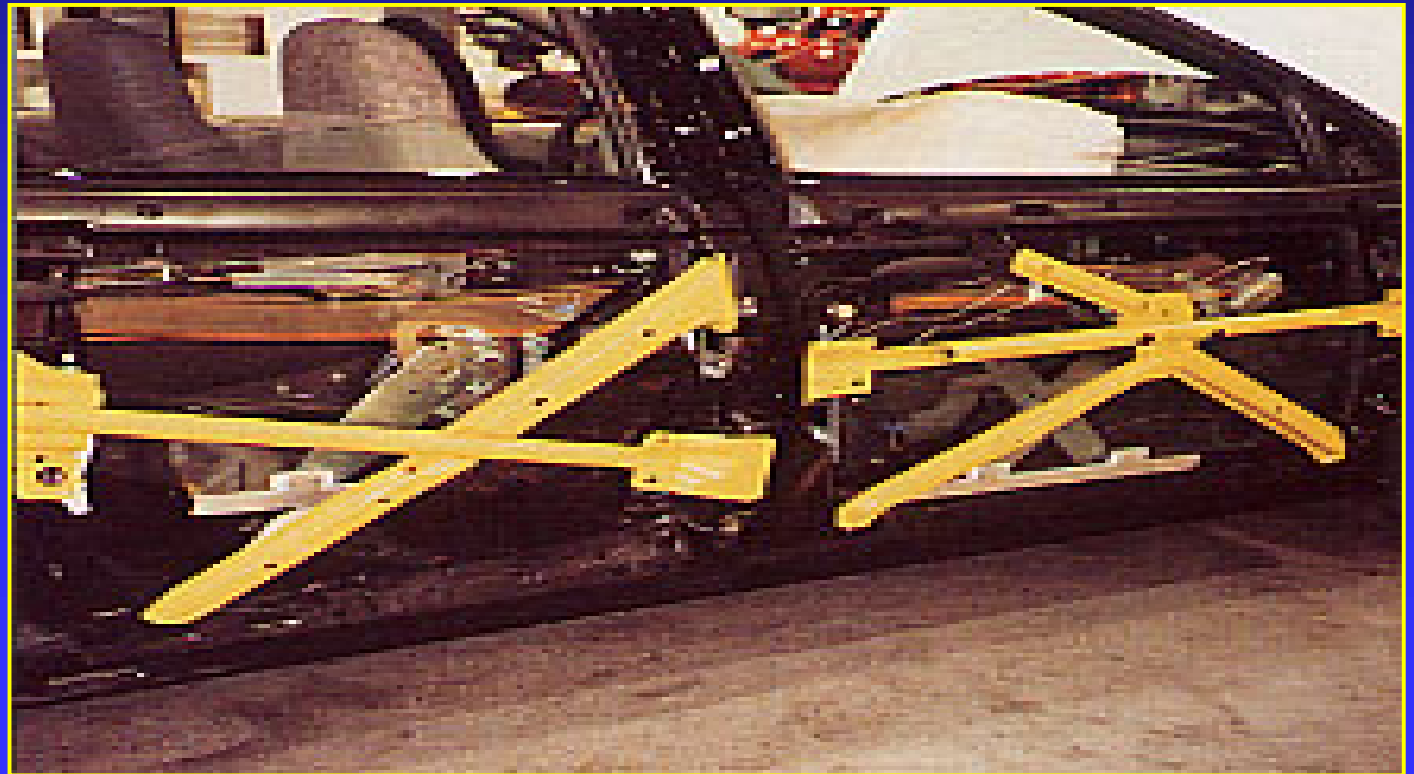



## Exterior Parts

# Doors

- Anyway you look at it. They are getting harder to get into.
- This calls for a new technique for rescue, (Window Spread) especially if the side bars have been jammed into the opposing posts due to the impact.

## Exterior Parts

# Doors LATCHES

- Traditional door handles operate a long lever mechanism that unlatches the positive latching mechanism of the nader pin.



## Exterior Parts

# Doors LATCHES

- This American automobile positive-latching design offers a two-point catch over the nader pin.

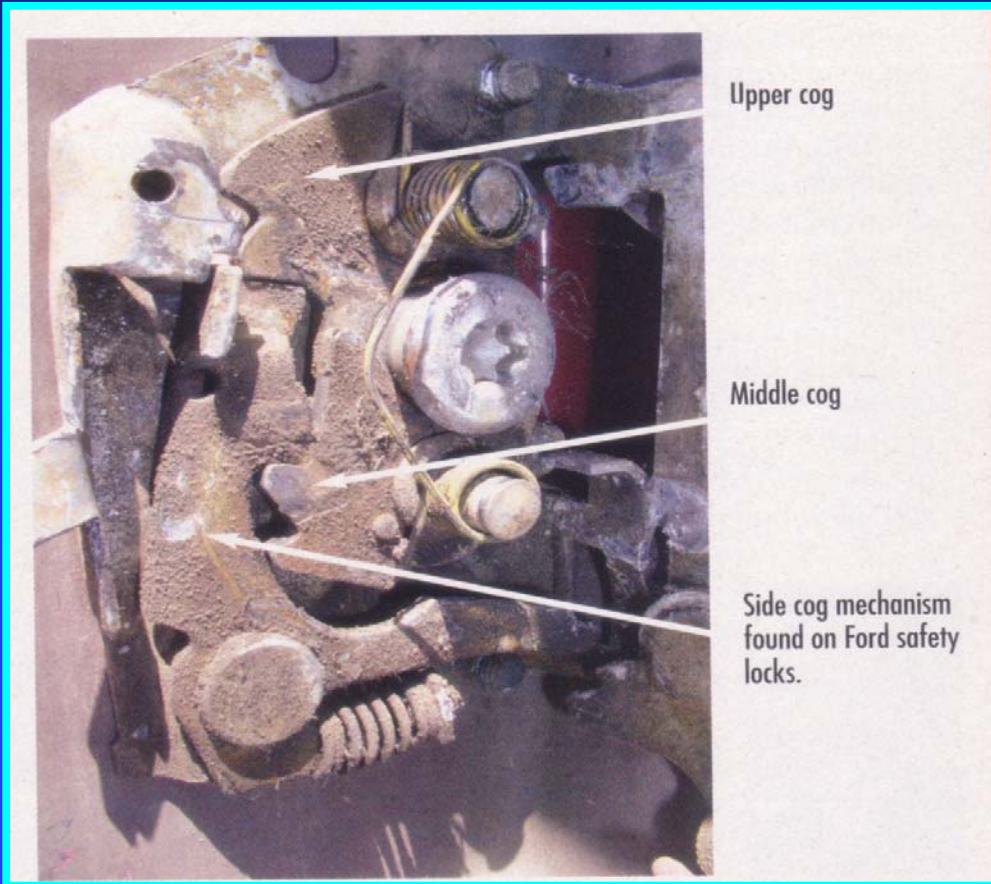



## Exterior Parts

# Doors LATCHES

- Foreign cars have radically different types of door latches and may pose a more difficult problem for the rescuer.
- Some German-made cars have a receiver that is a solid socket that accepts a latching pin and is solidly secured.



## Exterior Parts

# Doors LATCHES

- Asian cars have a latch mechanism that the door surrounds.
- During extrication it is common for the latch to remain intact.





## Exterior Parts

# Doors

### Rear Hatch or 5<sup>th</sup> Door

- Rear deck lid, or hatch on the hatch back or station wagon is usually lifted by means of pneumatic cylinders or torsion bars that are under pressure.
- **DO NOT CUT** such cylinder/bars.
- Use caution when cutting around them because they can literally fly up and out with violence.



## Exterior Parts

# Doors Rear Hatch or 5<sup>th</sup> Door

The 2003 Honda Element has changed everything...





## Exterior Parts

# Doors Rear Hatch or 5<sup>th</sup> Door

- 58% vehicle weight supported by front suspension system
- Composite boy panels
- Unit-body construction
- Seatbelt mounted on cargo doors



## Exterior Parts

# Doors

## Rear Hatch or 5<sup>th</sup> Door

- Occupant Position Detection System (OPDS) for front passenger side-impact airbags
- Front seatbelt pretensions
- Clamshell tailgate
- Rear seat stowing and recline features





## Exterior Parts

# Bumpers

- In 1973, it became law that the front bumpers on light vehicles were to be able to withstand a 5 mph impact.
- A year later, the rear bumpers were also included under this law.
- In order to comply, various methods of construction were employed to mount the bumpers in a way that would allow them to absorb shock and spring back into position.

# Exterior Parts Bumpers

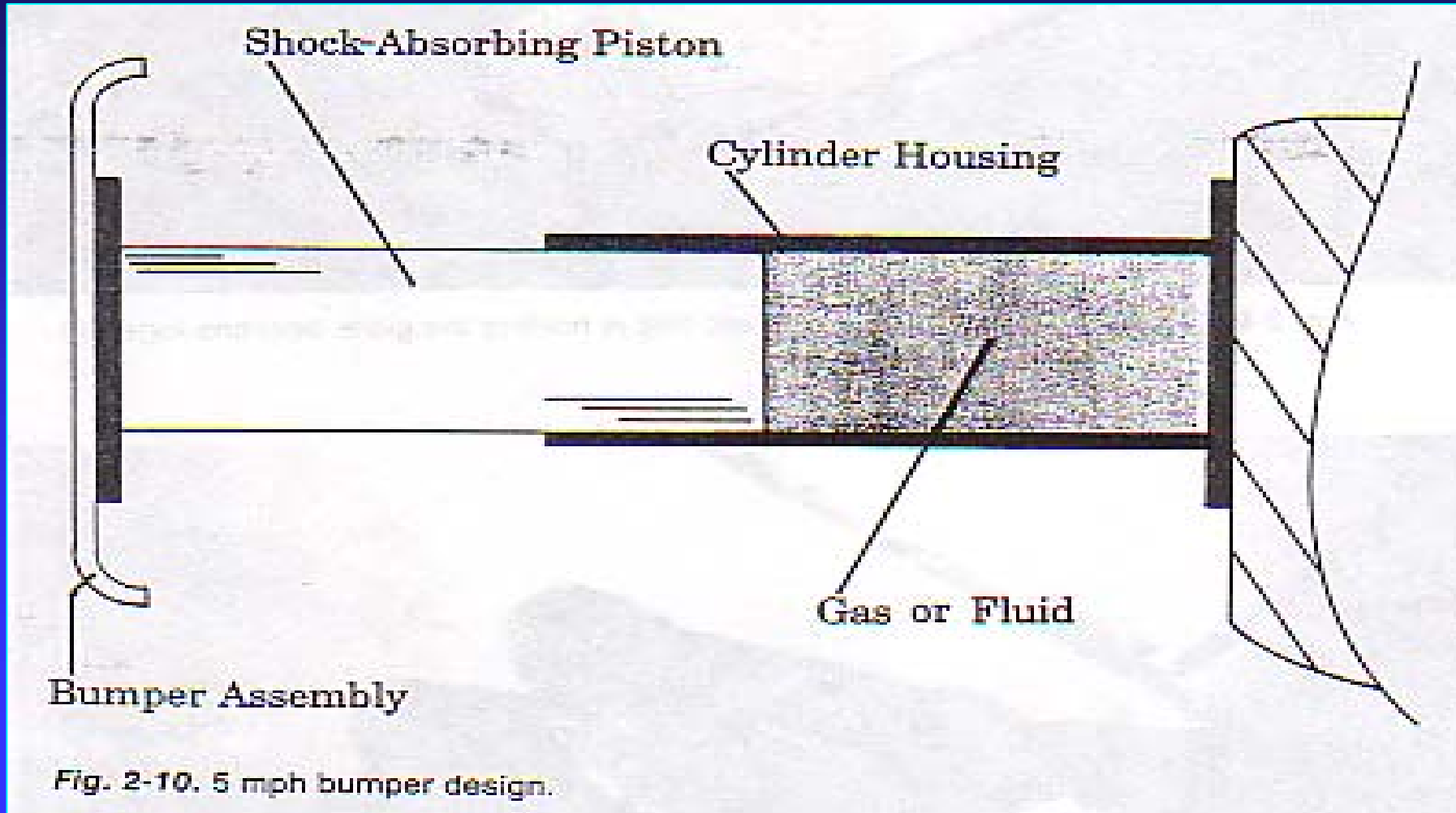

Fig. 2-10. 5 mph bumper design.



# Exterior Parts Bumpers



- **Warning: When exposed to heat from fire, drive shaft bumpers and gas filled struts can explode in a violent way.**



## Exterior Parts

# Bumpers

- The problem with shock-absorbing bumpers lie in their ability to store potential energy during a crash, when the bumper is compressed and becomes tangled in metal, remaining compressed afterward.
- Such unexpected releases can cause great injury to anyone in the path of the traveling bumper.



## Exterior Parts

# Bumpers and Struts

- The safest approach to use when you encounter a loaded bumper or strut is to avoid it. Therefore, it is essential to avoid approaching a vehicle directly from the front or rear during a fire or extrications.
- Approach at a 45 degree angle.

# Vehicle Fires



- Any motor vehicle with open flame visible upon your arrival is already a “Total Loss”

**Don't hurt yourself!**

Video

Holmatro 6



# Vehicle Fires

- Common in most communities
- Important to wear SCBA
- Use 1 1/2" or 1 3/4" hose line
- Vehicles have shock absorbers, bumpers, and trunk/hatchback components that are gas-filled and may burst.
- Consider other hazards.



# Fires under the Hood (1 of 3)

- Approach from uphill and upwind at a 45° angle.
- Direct water into wheel wells and through the front grill.
- Wheels should be chocked.





# Fires under the Hood (2 of 3)

- Pull hood release latch.
  - ◆ If successful trip secondary latch
  - ◆ If not, use a Halligan to pry up a corner on the hood.
  - ◆ Or, break the grill, cut the release cable and pull with pliers
  - ◆ Or, use a rotary saw to cut the latch from the hood
- Open the hood and extinguish fire.
- Care should be used to prevent splashing battery acid.



# Fires under the Hood (3 of 3)

- Consider leaking fluids that may be flammable.
- Overhaul same as a structure fire
- Use water liberally if significant damage has already occurred.



# Fires in the Passenger Area

- Approach from upwind at 90° angle.
- Use straight stream from 50' and approach with slow, sweeping motion.
- Change to a fog when closer
- Foam can be used for any burning flammable liquids.
- Begin overhaul after steam clears.
- Do not place yourself in path of airbags.



# Fire in the Trunk

- Use a Halligan tool to force the lock for entry.
- Charged line must be ready.
- Approach with caution; may have a variety of hazards inside.



# Alternative Fuel Vehicles (1 of 3)

- Be alert for these vehicles.
- Use unmanned master streams.
- Compressed Natural Gas (CNG).
  - ◆ Cylinders similar to SCBA cylinders
  - ◆ Usually in the trunk
  - ◆ Nontoxic and lighter-than-air



# Alternative Fuel Vehicles (2 of 3)

- Liquefied Propane Gas (LPG)
  - ◆ Cylinders similar to those in heating/cooking
  - ◆ Heavier than air, vapors will pool or collect in low areas.



# Alternative Fuel Vehicles (3 of 3)

## ■ Hybrid vehicles

- ◆ Small gasoline motors and large battery banks
- ◆ Batteries are very hazardous and may explode when burning.
- ◆ Runoff is hazardous
- ◆ High voltage lines can cause serious injury or death if cut.



# Exterior Parts Bumpers

**Verdugo Fire Academy**

**Ch.25**

... more than fighting fires





# FIREFIGHTER INJURY

**JULY 26, 1998  
0220 HOURS**

**VEHICLE FIRE  
ENGINE COMPARTMENT**

**Vehicle Hood Strut  
Explosion**

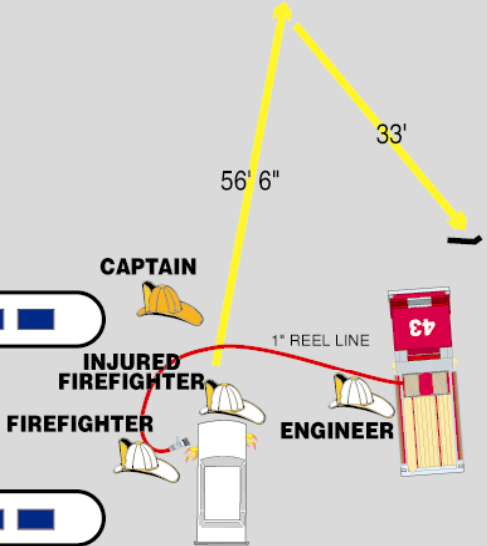
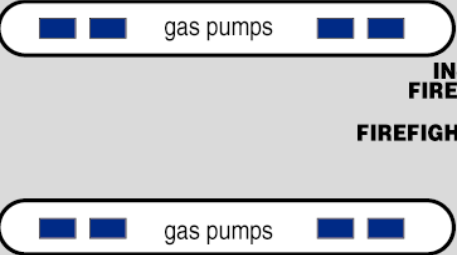
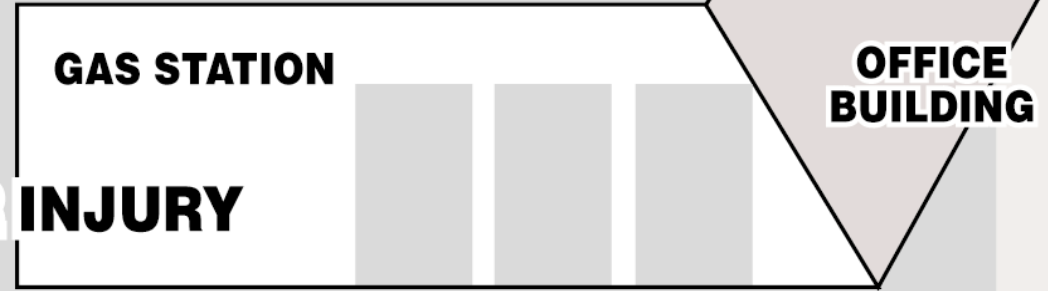

**Second strut  
bounced  
off building  
and  
landed in  
parking lot**





# Exterior Parts Bumpers

## Enough Said...





# Exterior Parts Bumpers

## Get the point?





# Exterior Parts Struts





# Exterior Parts Struts

**Verdugo Fire Academy**

**Ch.25**

... more than fighting fires





# Exterior Parts Wheels

- Automobile wheels have changed little since World War II.
- The car can rock from side to side on its tires during rescue if the automobile has not been properly stabilized prior to extrication.





# Exterior Parts Wheels

- This later motion can also displace conventional cribbing if the tires are not deflated during the stabilization process.





# Exterior Parts Wheels

- Step cribbing is essential to control movement.





## Exterior Parts Wheels

- Discussing tires and wheels, one has to mention the topic of split rims.
- Split rims, or two-piece rims, present serious hazards to rescuers and to anyone else who encounter them.

## Exterior Parts

# TRUNK CARGO COMPARTMENT

- The trunk of the automobile can house the fuel tank, batteries, hazardous cargos, or even people, in extreme cases.



DON BARTLETT / Los Angeles Times  
Border Patrol checks car with suspected illegal immigrants in trunk. . .





## Exterior Parts

# ENGINE COMPARTMENT

- The engine compartment of a modern automobile is crammed full of surprises.

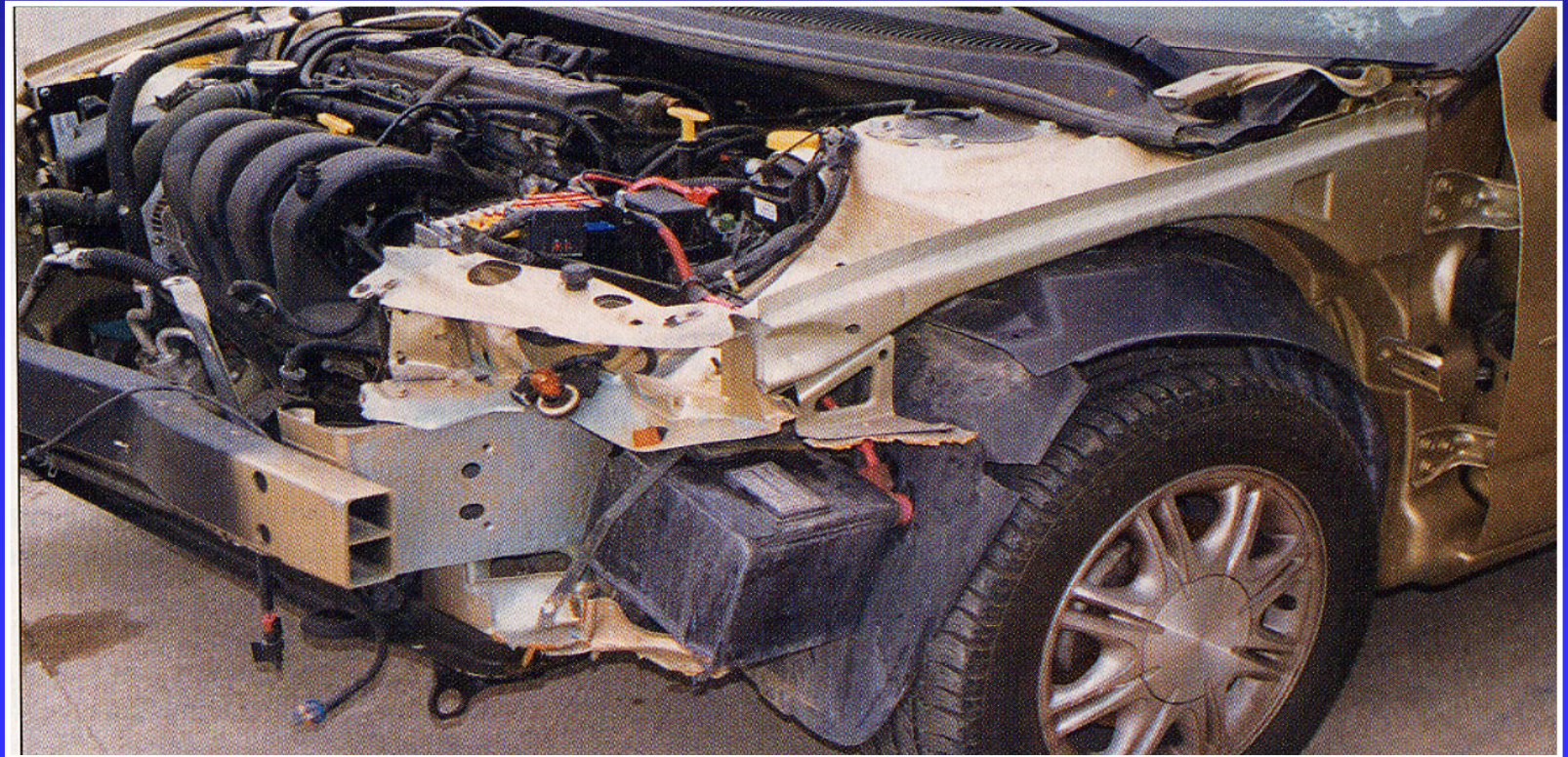

## Exterior Parts

# ENGINE COMPARTMENT

- If possible, a rescuer, should pull the inside hood release to allow access to the engine compartment.
- Once access is gained, steps should be taken to render the obvious hazards safe.



## Exterior Parts

# FUEL SYSTEMS

- Fuel tanks on today's automobiles may be found anywhere in the vehicle, including directly behind or even between the front seats.
- **DO NOT ASSUME THE TANK IS UNDER THE TRUNK OF THE CAR.**





**Verdugo Fire Academy**

... more than fighting fires

**Ch.25**

# Video

## Gas Vapor Explosion



## Exterior Parts

# FUEL SYSTEMS

- Most vehicles use two fuel lines to transfer fuel between the fuel tank and the engine.
  - ◆ One line from the tank to the engine.
  - ◆ One line returns unused fuel back to the tank.
- After market propane gas system and electric cars are also becoming more commonplace.



## Exterior Parts

# ELECTRICAL SYSTEMS

The heart of the electrical system is the battery already discussed earlier.

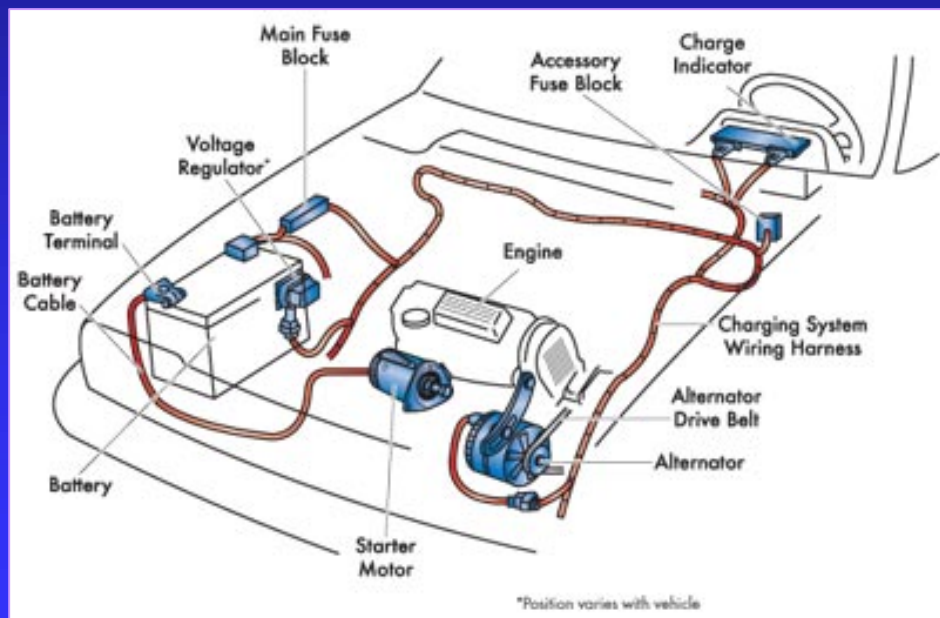

INTERNAL COMPONENTS

**Spiralcell Technology**  
for superior vibration resistance and extended life

**Solid Cast Cell Connections**  
for increased durability and maximum plate height

**99.999% Pure Lead**  
Spiralcell design allows for lead to be used in its purest form

**Absorbent Glass-Mat Separators**  
holds electrolyte like a sponge to eliminate acid spilling

**Tightly Compressed Cells**  
for added vibration resistance



# INTERIOR PARTS

## STEERING WHEEL AND COLOMN

Prior to the mid-1960's, the steering column of an automobile was a solid piece of tool steel. Today the column is usually a hollow tube surrounded by plastic, designed to collapse on impact in a shock-absorbing motion.

# INTERIOR PARTS

## STEERING WHEEL AND COLOMN

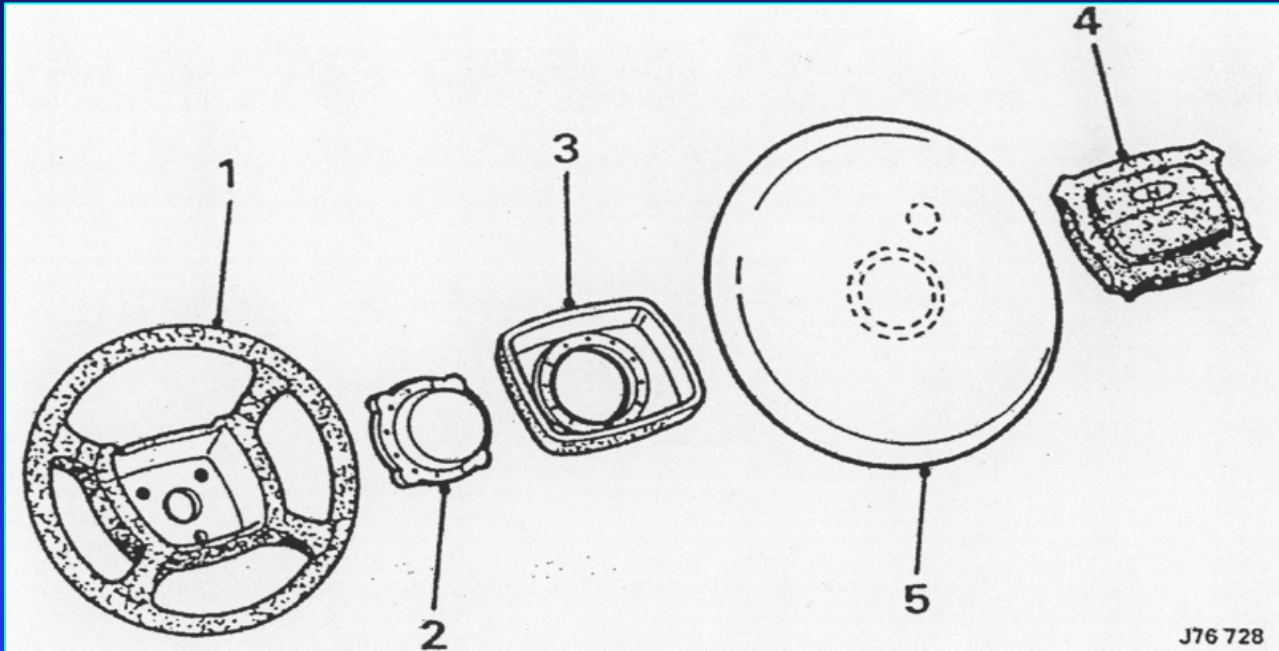

J76 728

### Components of the Air Bag Module

1. Steering Wheel
2. Inflator/Sensor Assembly
3. Inflator/Sensor Housing
4. Module Trim Cover
5. Air Bag

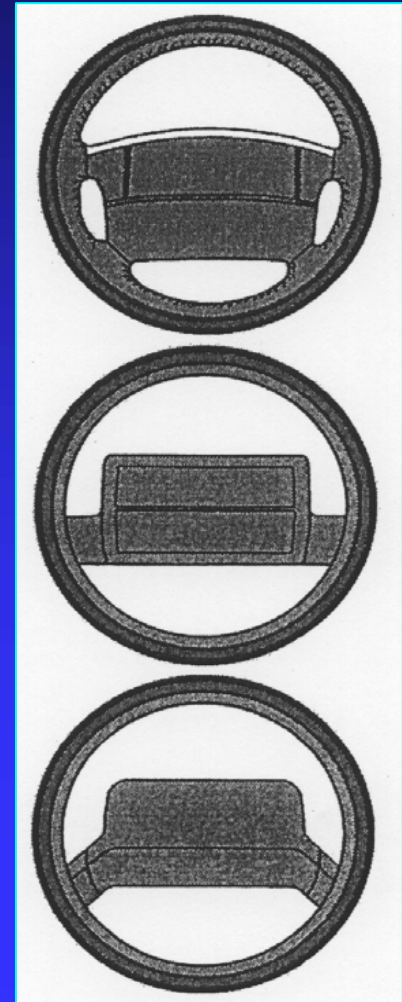



## INTERIOR PARTS

# STEERING COLOMN

In cars with front-wheel drive, a joint in the column may be found at the floorboard or higher up the column in the passenger compartment.

**- USE CAUTION: potential injury to the patient may occur from this (universal) joint fling out toward the patient during a dash roll.**



**Verdugo Fire Academy**

... more than fighting fires

**Ch.25**

# Video

0985 to 1404  
Holmatro 5



## INTERIOR PARTS

# AIR RESTRAINT BAGS

- Beginning with the 1990 model year, auto makers were required by federal law to provide a passive restraint system in every passenger car sold in the United States.
- These passive restraint systems may be either automatic, motorized seat belts or air bags combined with manual seat belts.

## INTERIOR PARTS

# AIR RESTRAINT BAGS

- Air bags are a safety feature that has saved countless lives and prevented serious injuries to the driver of a vehicle involved in a front or near frontal collision



## INTERIOR PARTS

# AIR RESTRAINT BAGS

- Such bags protect the occupants of the vehicle by rapidly inflating a bladder with nitrogen, to provide a protective cushion between the driver and the vehicle.





## INTERIOR PARTS

# AIR RESTRAINT BAGS

- Some things to know about air bags:
  - ◆ Designed to deploy in a 30 mph crash.
  - ◆ Designed to work on an 130 pound person setting directly back in there seat.
  - ◆ Only deploy one time, additional impacts are unprotected **until 2003**.
  - ◆ **Note: 14** is the largest number of airbags in a know vehicle as of 2007.



## INTERIOR PARTS

# AIR RESTRAINT BAGS

- **Some more things to know about air bags:**
  - ◆ **1<sup>st</sup> Generation deployed at 140 mph**
  - ◆ **2<sup>nd</sup> Generation deploy at 80 to 120 mph**
  - ◆ **Statistic's show that the only position that has improved with airbags is the driver. Until the introduction of side tubular or curtain air bags in the late 90's**
  - ◆ **Gas pressure of 1,400 to 3000 psi.**



## INTERIOR PARTS

# AIR RESTRAINT BAGS

- **Some more things to know about air bags:**
  - ◆ Air bags can deploy so violently that they break the wind shield of the car. As an EMT don't mistake this for a head impact
  - ◆ Also, air bag wiring is traditionally yellow wiring but as of 2005 yellow & black and, just black are now being seen. (You can't tell any more.)





## INTERIOR PARTS

# AIR RESTRAINT BAGS

## Warning:

**Any time you are working in the interior of a vehicle, be aware of undeployed airbags. Keep a safe distance between yourself, the patient, and the undeployed airbag.**

## INTERIOR PARTS

# AIR RESTRAINT BAGS

- All side-impact airbag systems (seat, door or roof-mounted) use stored gas inflator modules containing pressures up to 3,000psi.

In other words you will not win. Use the following numbers to keep yourself out of trouble...





## INTERIOR PARTS

# AIR RESTRAINT BAGS

**Practice the “5-10-20” Rule**

**Side Impact/Curtain Airbags**

**Safe Distance is 5 inches or more**

**Driver Side Front Airbags**

**Safe Distance is 10 inches or more**

**Passenger side front airbags  
& Convertibles**

**Safe Distance is 20 inches or more**

## INTERIOR PARTS

# AIR RESTRAINT BAGS

- The typical air bag restraint system is located on the driver's side, in the steering wheel hub.

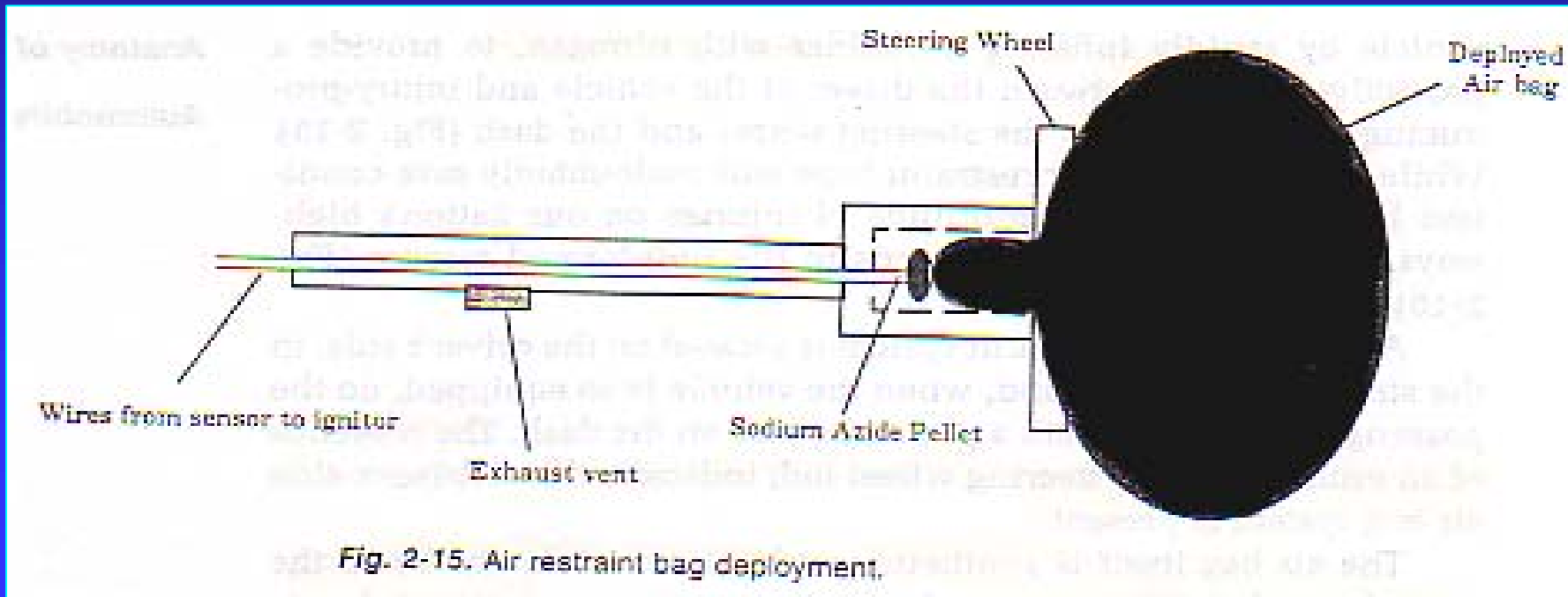

# INTERIOR PARTS

# AIR RESTRAINT BAGS

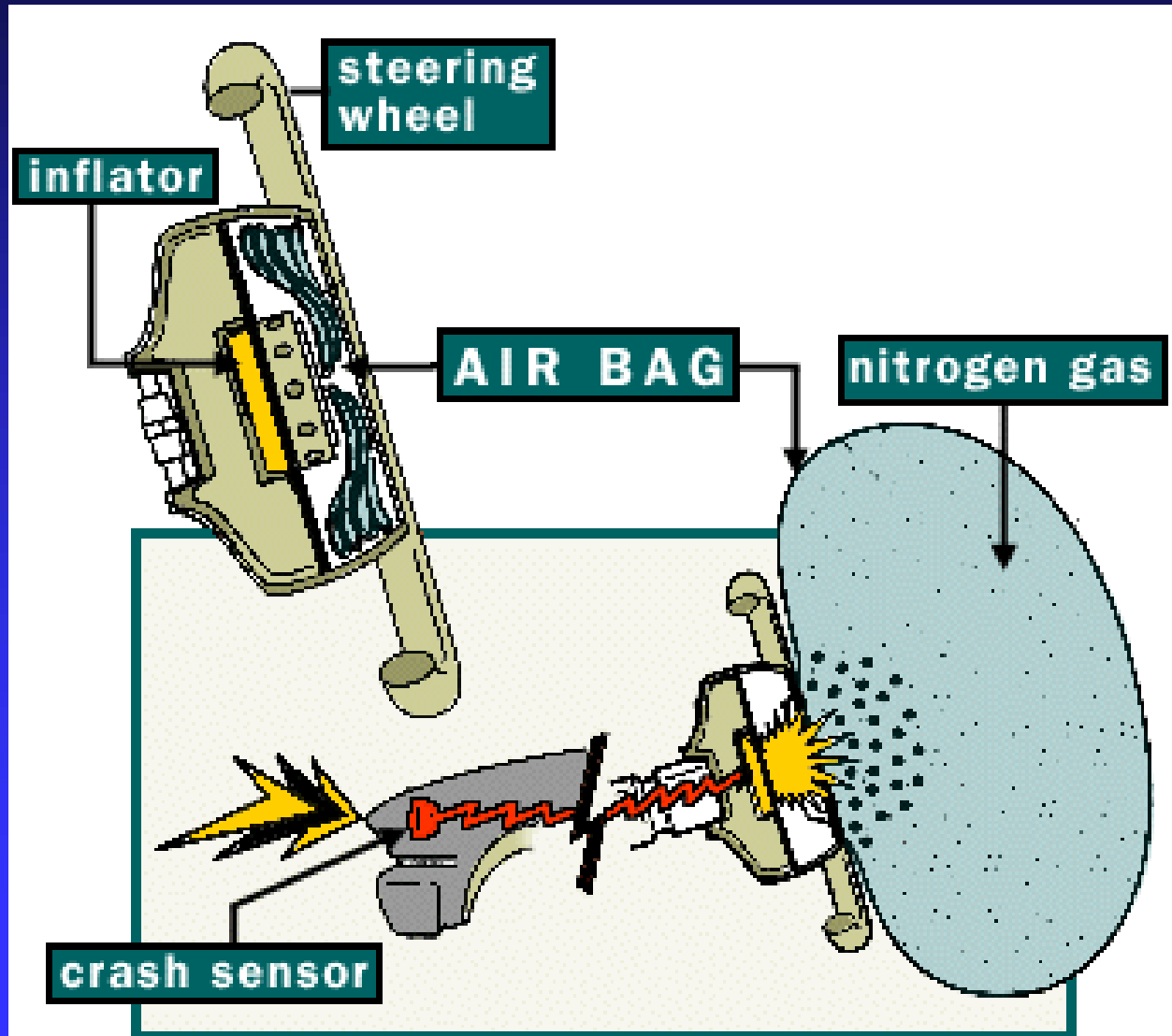



## INTERIOR PARTS

# AIR RESTRAINT BAGS

- The airbag itself is synthetic, made of materials similar to the typical hyaline salvage cover.
- **Air bags are not intended to be the ultimate sole protection. They must be used in conjunction with manual seat belts for proper performance.**
- Sensors are set to react to a force of more than 8 but not more than 14 mile per hour.



## INTERIOR PARTS

# AIR RESTRAINT BAGS

- Starting in the 2001 Honda Civic vehicles were equipped with smart seats:
  - ◆ 40 lbs. to activate
    - ◆ No weight, no go
  - ◆ Will be required in all 2008 vehicle
    - ◆ Warning: don't you be the weight

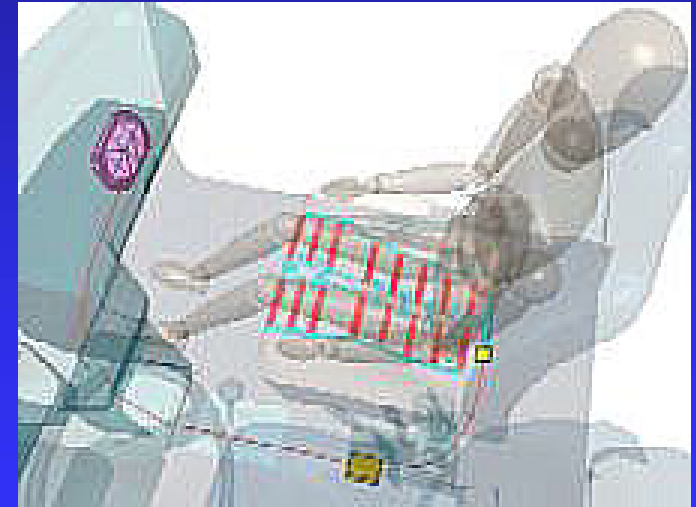

## INTERIOR PARTS

# AIR RESTRAINT BAGS

- They must be used in conjunction with manual seat belts for proper performance.

- Pretensioners:

- ◆ Two types

- ◆ Belt

- ◆ Buckle

Explosive  
charges

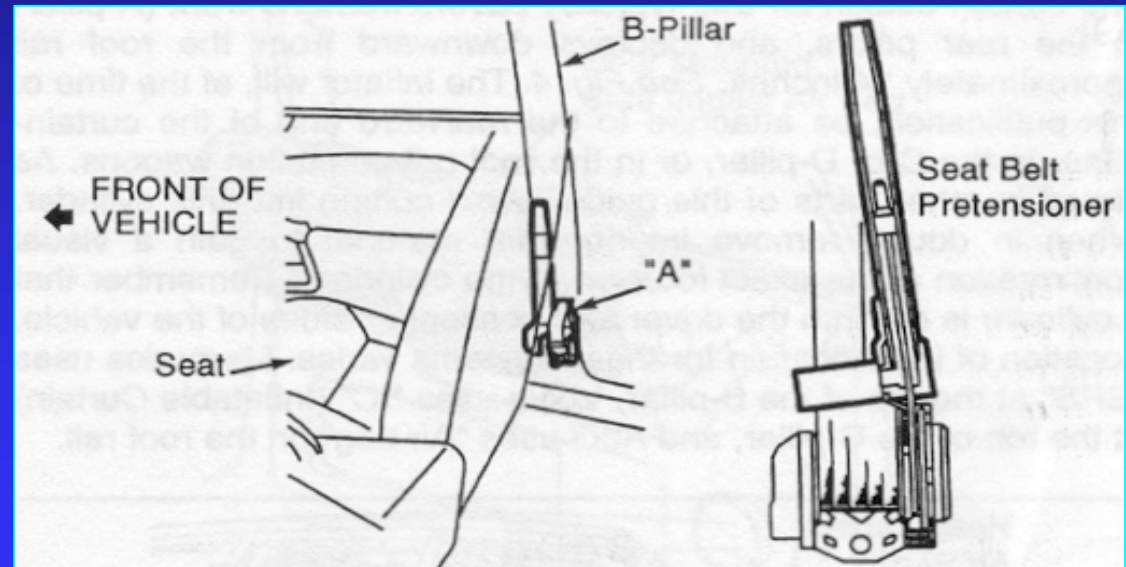

# AIR RESTRAINT BAGS

- Pretensioners are activated by way of a pyrotechnic charge. Once the charge is ignited, the subsequent explosion triggers the activation of the pretensioner. Note: the reinforced steel adjustable seatbelt plate.

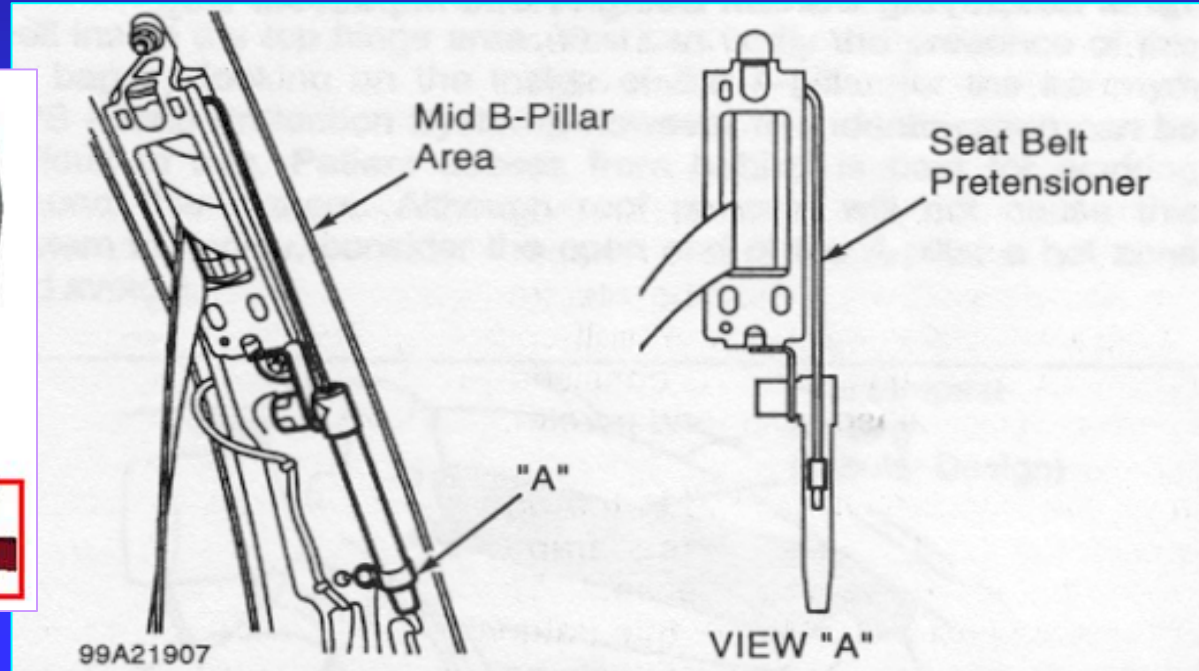
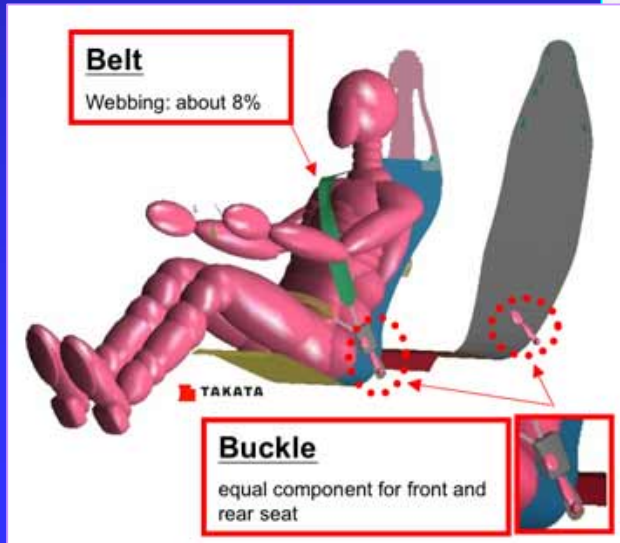



## INTERIOR PARTS

# AIR RESTRAINT BAGS

- General Motors (2001) All-Belts-To-Seat design seatbelts has been copied by Ford's 2003 model F-series. The seatbelt system is integrated into the seat itself; the pyrotechnic seat belt pretensioner unit is in the female seatbelt buckle. When deployed the buckle drops several inches.



## INTERIOR PARTS

# AIR RESTRAINT BAGS

- Once activated and only taking less than 2 volts to do so, they send a signal to a detonator which then burns approximately 80 grams of chemical sodium azide.

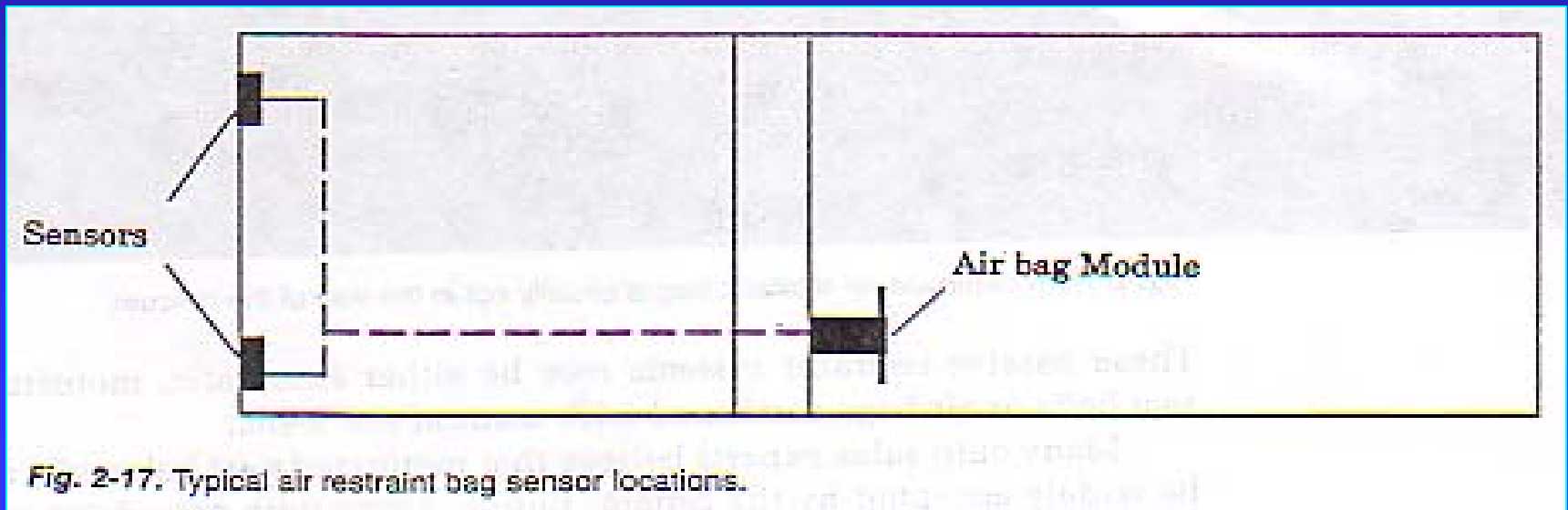
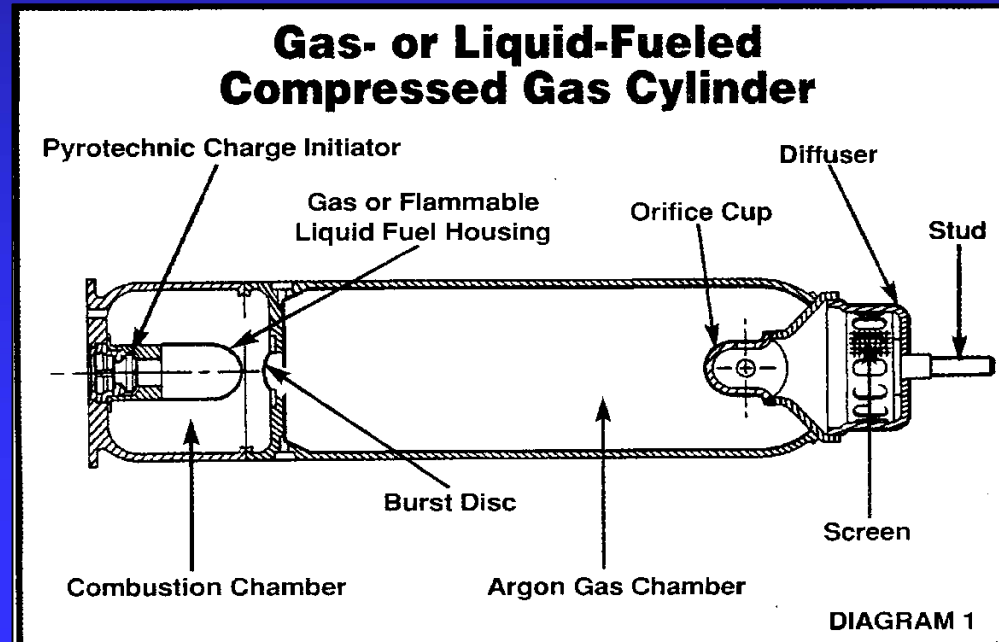

Fig. 2-17. Typical air restraint bag sensor locations.

# AIR RESTRAINT BAGS

- Witnesses describe the sound as a 12-gauge shotgun.
- The gas (nitrogen) created by the activation is hot and can cause burns.





## INTERIOR PARTS

# AIR RESTRAINT BAGS

- Azide is a skin, eye and mucus membrane irritant. If it comes into contact with water, it will burn rapidly with what some call a “loud report.”
- The ignition burning of sodium azide creates a white, chalky, slightly alkaline powder.

## INTERIOR PARTS

# AIR RESTRAINT BAGS

- The sequence of events that takes place when an air bag system is deployed is as follows:
  1. The Incident
  2. Ignition
  3. Expansion
  4. Deployment
  5. Deflation





## INTERIOR PARTS

# AIR RESTRAINT BAGS

- **The incident:** The sensors detect the frontal or near frontal impact and react to the negative g forces (the backward movements) imposed by the impact.
- If two of the sensors detect the crash, they then send an electronic signal to the ignition mechanism.



## INTERIOR PARTS

# AIR RESTRAINT BAGS

- If two of the sensors detect the crash.

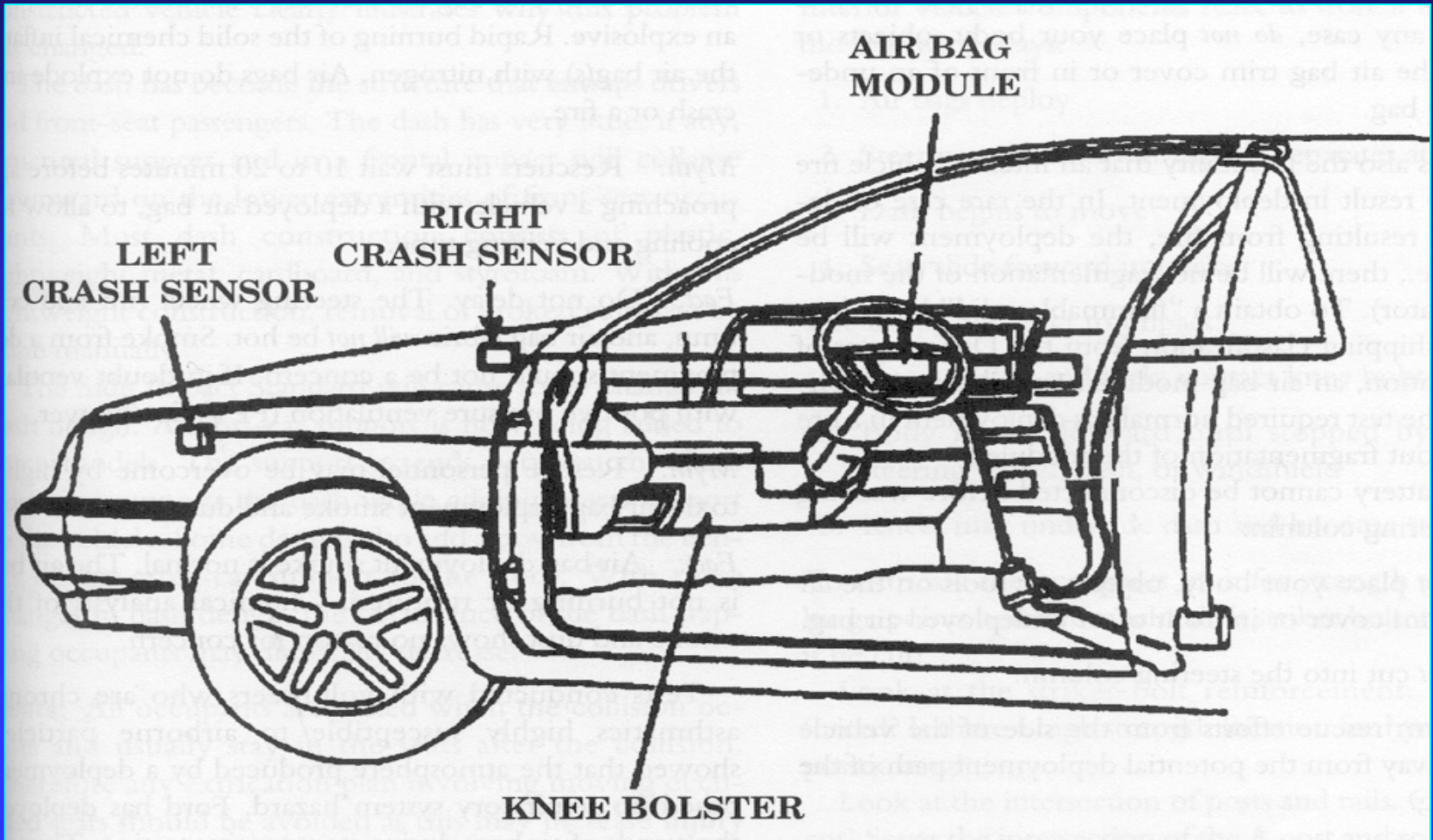

## INTERIOR PARTS

# AIR RESTRAINT BAGS

- **Ignition:** The ignition mechanism receives the signal to fire and ignites the rapid-burning sodium azide.

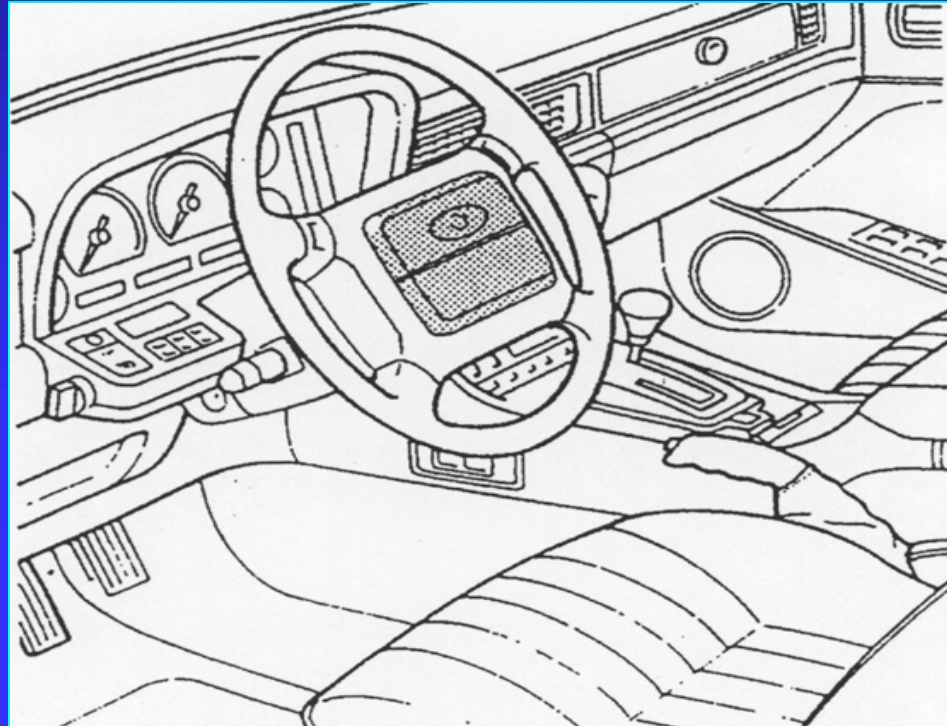

## INTERIOR PARTS

# AIR RESTRAINT BAGS

- **Expansion:** The sodium azide explodes and immediately produces the nitrogen required to fill the air bag rapidly.

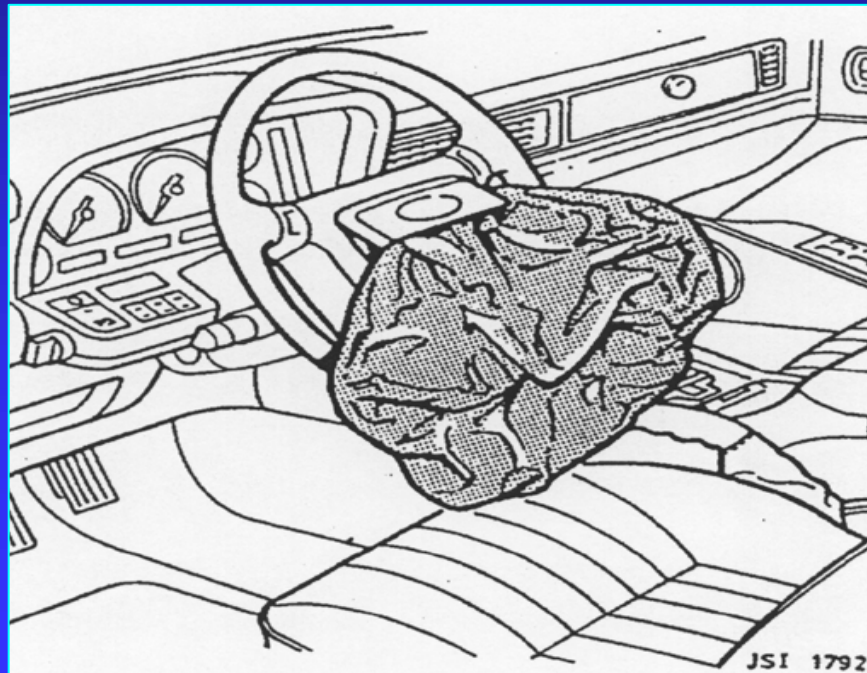

Deployed Air Bag

## INTERIOR PARTS

# AIR RESTRAINT BAGS

- **Deployment:** The airbag deploys, emerging from behind a lightweight plastic panel, and cushions the occupant from the frontal impact. (Such plastic panels are designed to swing out of the way and avoid striking the occupant.)





## INTERIOR PARTS

# AIR RESTRAINT BAGS

- These first four steps of the sequence of events:
  1. Incident
  2. Ignition
  3. Expansion
  4. Deployment
- Take less than 1/20<sup>th</sup> of a second.
- Which is faster than you can blink your eye.



## INTERIOR PARTS

# AIR RESTRAINT BAGS



- **Deflation:** Once the air restraint bag has done its job, the nitrogen is exhausted through vent at the side of the steering column, toward the driver's feet.



## INTERIOR PARTS

# AIR RESTRAINT BAGS

**Another potential hazard is accidental activation of an Air Bag:**

- The process is accomplished by disconnecting the negative side of the electrical supply (battery). A capacitor used to deploy the bag in case of electrical failure can still fire the system, but it will lose its charge during the next few minutes to few hours.



# AIR RESTRAINT BAGS

- Do not delay rescue efforts while waiting for the charge to decay, remain clear of the immediate area of the air bag.
  - ◆ Use your numbers





## INTERIOR PARTS

# AIR RESTRAINT BAGS

**UPDATE:** Some advertised it, some haven't, dual-deployment or dual stage frontal airbags. These systems contain 2 charges, one big & one small. Volvo and others...





# AIR RESTRAINT BAGS

## Air Bags are Located:

- Driver and passenger Air Bag
- Knee Impact Air Bag
- Side Impact Air Bag (Seat)
- Side Impact Air Bag (Door)
- Roof Rail (tubular and curtain designs)
- Convertible rollbar designs
- Back seats



## INTERIOR PARTS

# AIR RESTRAINT BAGS

- Where do you look to see if it has one?

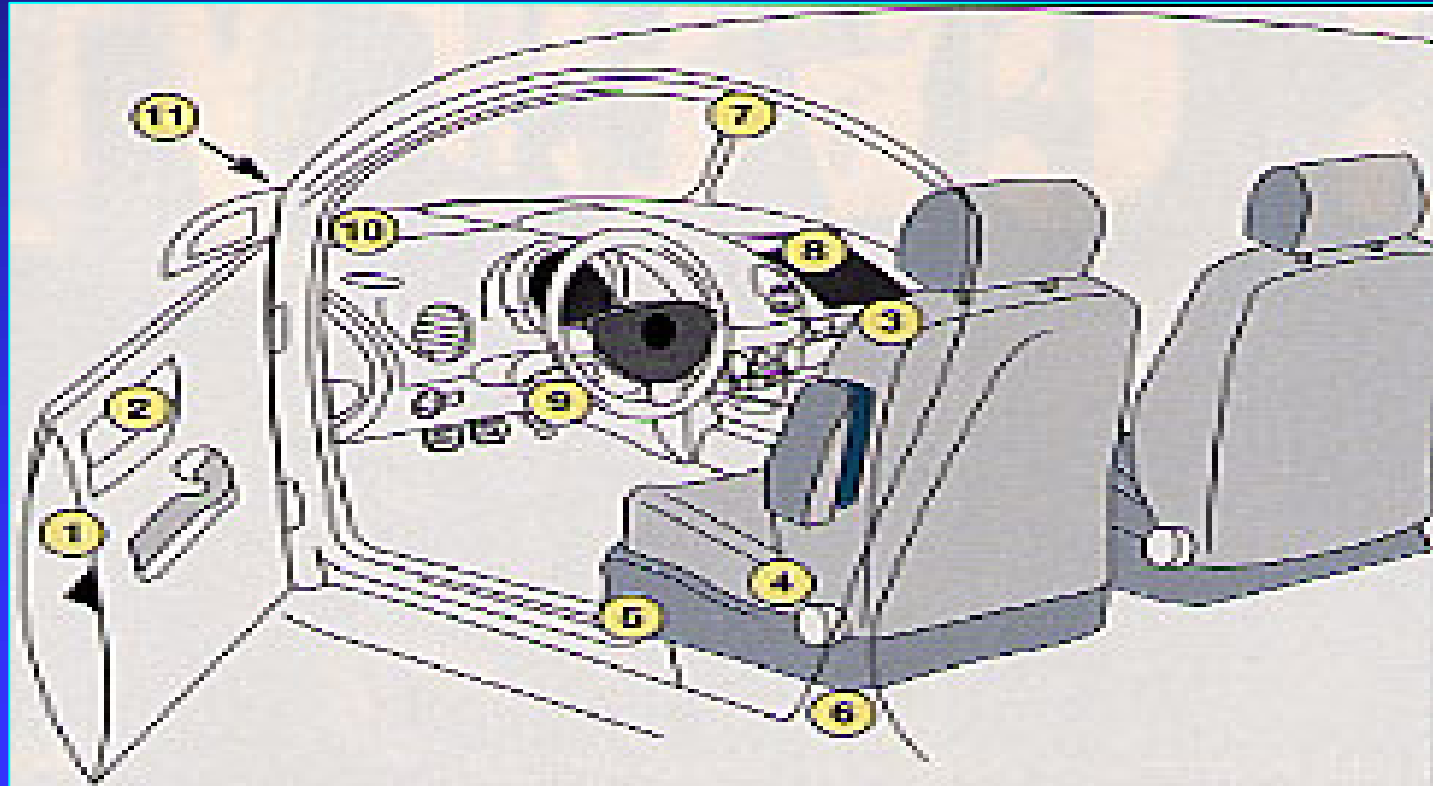



## INTERIOR PARTS

# AIR RESTRAINT BAGS

**Verdugo Fire Academy**

**Ch.25**

... more than fighting fires





# INTERIOR PARTS

# AIR RESTRAINT BAGS

**Verdugo Fire Academy**

**Ch.25**

... more than fighting fires

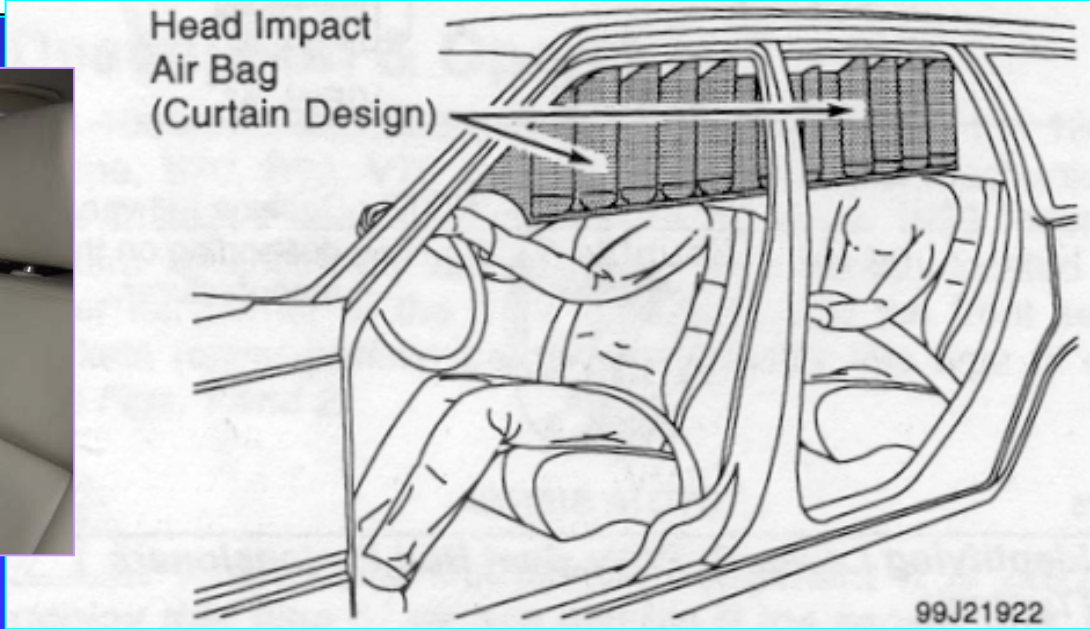
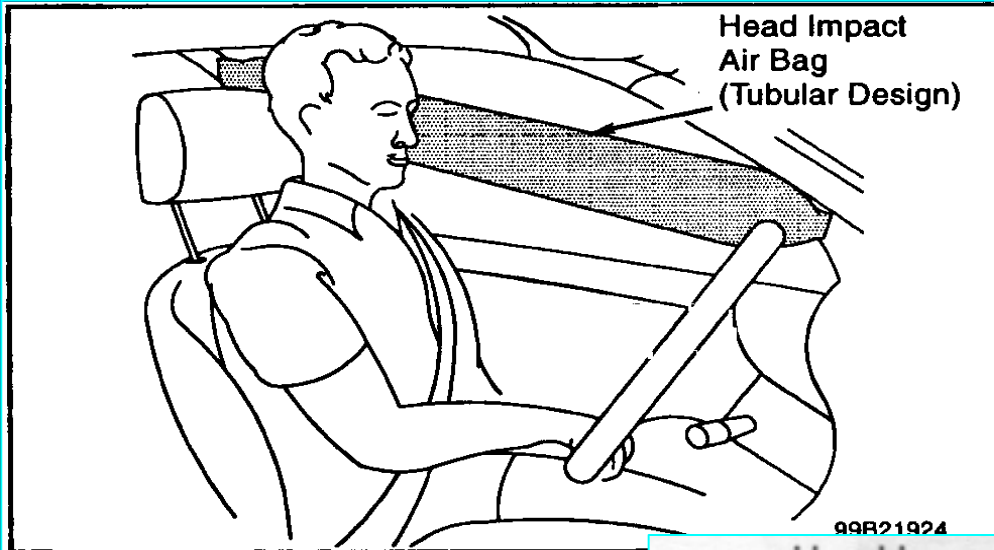



## INTERIOR PARTS

# AIR RESTRAINT BAGS

**UPDATE:** Starting in 2003 and continuing to present Mercedes and BMW continue to store gas inflator modules for roof-mounted air bag systems located on the A-Pillars.

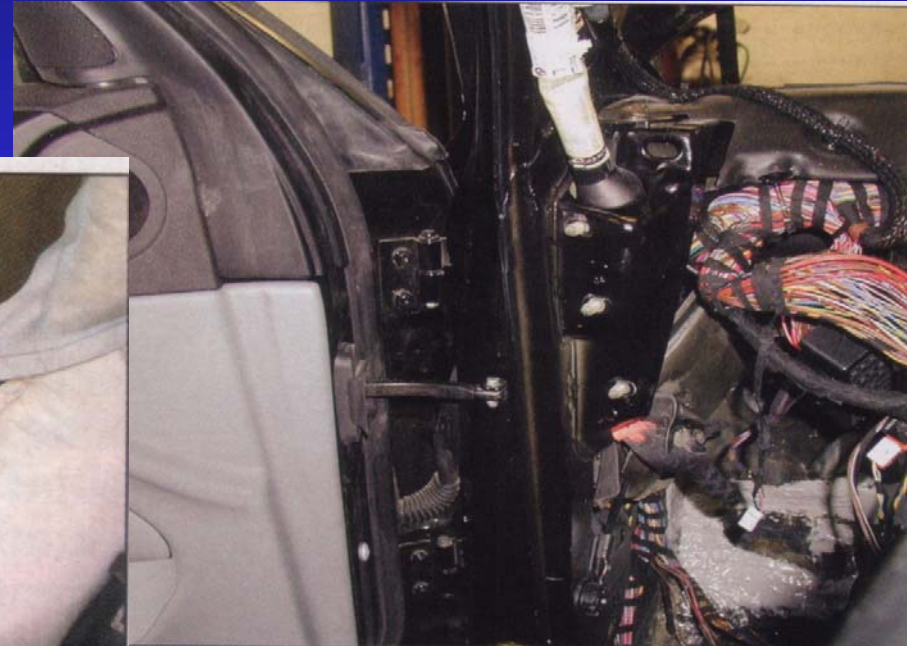



## INTERIOR PARTS

# AIR RESTRAINT BAGS

**WARNING:** To overcome stored gas inflator modules located in the A-Pillars, expose by stripping the trim before you cut. **“Strip and Peek” is the Golden Rule here!**

If you don't see it, it may be in the roof rails but it is there.

Once you see these systems, one can work around them, you just have to know they're there. Surprises stink on the rescue scene.

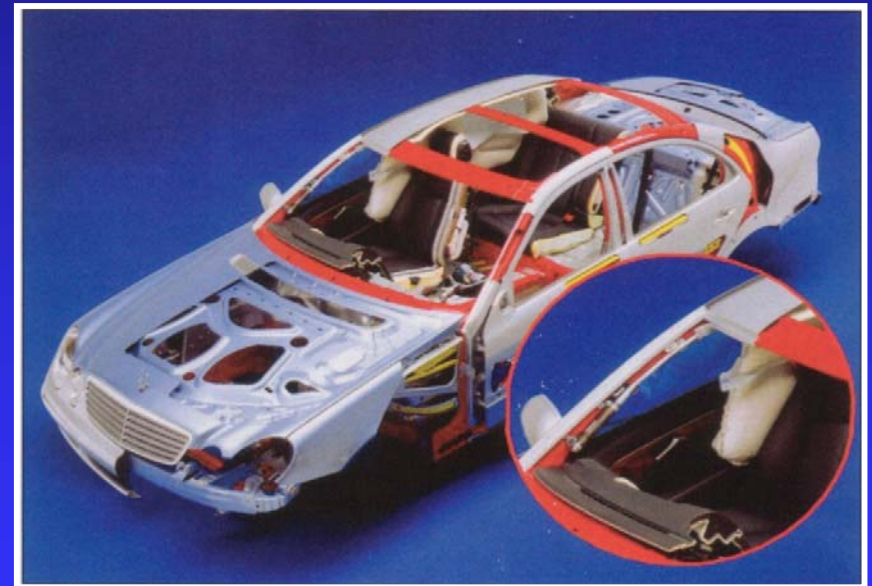



## INTERIOR PARTS

# AIR RESTRAINT BAGS

**Warning:** Ford offers roof airbags in SUV's in the 2004 Expedition and other manufactures have followed. The bag covers 2/3's of the first and second row side window opening and stays inflated longer for rollover and side impact protection.



Currently, it is safe to physically cut the roof airbag open and move or remove it from the patient work area.



## INTERIOR PARTS

# AIR RESTRAINT BAGS





# INTERIOR PARTS

# AIR RESTRAINT BAGS

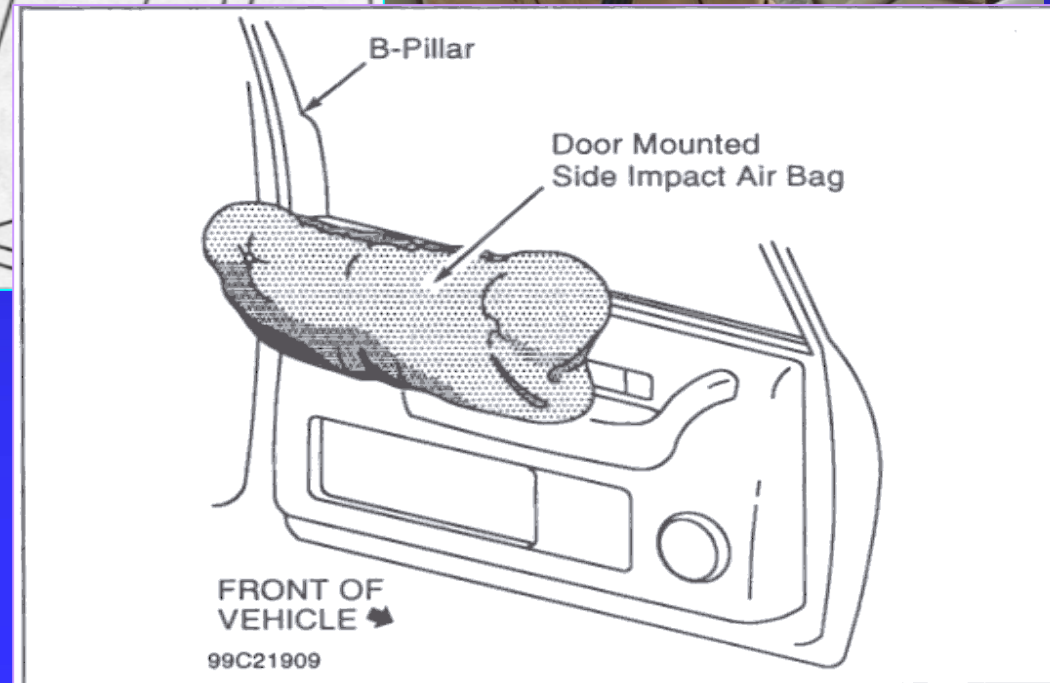
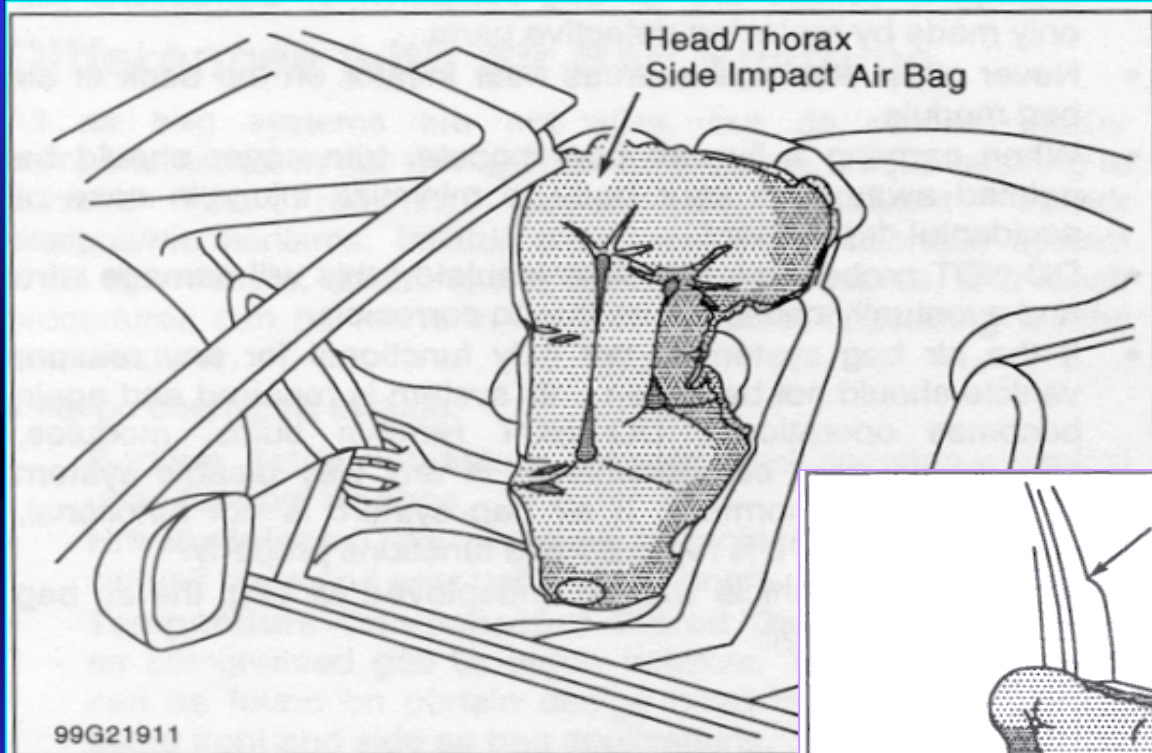



## INTERIOR PARTS

# AIR RESTRAINT BAGS

**Verdugo Fire Academy**

**Ch.25**

... more than fighting fires





## INTERIOR PARTS

# AIR RESTRAINT BAGS

**WARNING:** Many manufactures are now hiding Airbag ID's, it started in 2004 with Volvo's SUV. Safety equipment is now so common people don't want to see it, so there are non air bag ID's anywhere on the vehicle.



## INTERIOR PARTS

# AIR RESTRAINT BAGS

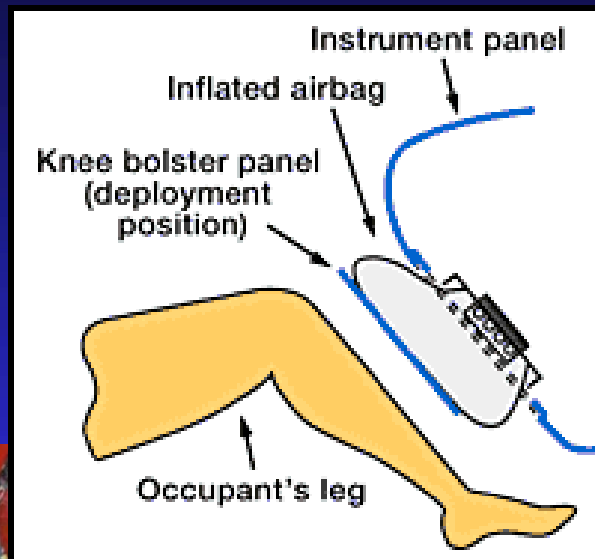

- In 1995 the KIA knee bag was introduced & never touches the driver. It pushes the instrument panel knee “bolster” panel outward to contact the driver.
- ◆ Note: Bag added to solve the problem of the lowest crash test rating now in Audi, BMW and Chrysler.



## INTERIOR PARTS

# AIR RESTRAINT ROLLBARS

**Warning:** The 2004 Audi A4 Cabriolet has a “active rollover protection system, (deployable bars).

**Note:** This works like the other systems in the car and may deploy without rollover.

**DO NOT COVER**





**Verdugo Fire Academy**

... more than fighting fires

**Ch.25**

# Video

1404 to 2031  
Holmatro 7



**Verdugo Fire Academy**

**Ch.25**

... more than fighting fires

# TAKE 5





# Extrication Walk-thru

**Verdugo Fire Academy**

**Ch.25**

... more than fighting fires





# Extrication Walk-thru

**Verdugo Fire Academy**

**Ch.25**

... more than fighting fires





# Extrication Walk-thru

**Verdugo Fire Academy**

**Ch.25**

... more than fighting fires





# Newer model cars to defeat the side impact bars Extrication Walk-thru

**Verdugo Fire Academy**

**Ch.25**

... more than fighting fires





# Extrication Walk-thru

**Verdugo Fire Academy**

**Ch.25**

... more than fighting fires





# Extrication Walk-thru

**Verdugo Fire Academy**

**Ch.25**

... more than fighting fires





# Extrication Walk-thru

**Verdugo Fire Academy**

**Ch.25**

... more than fighting fires

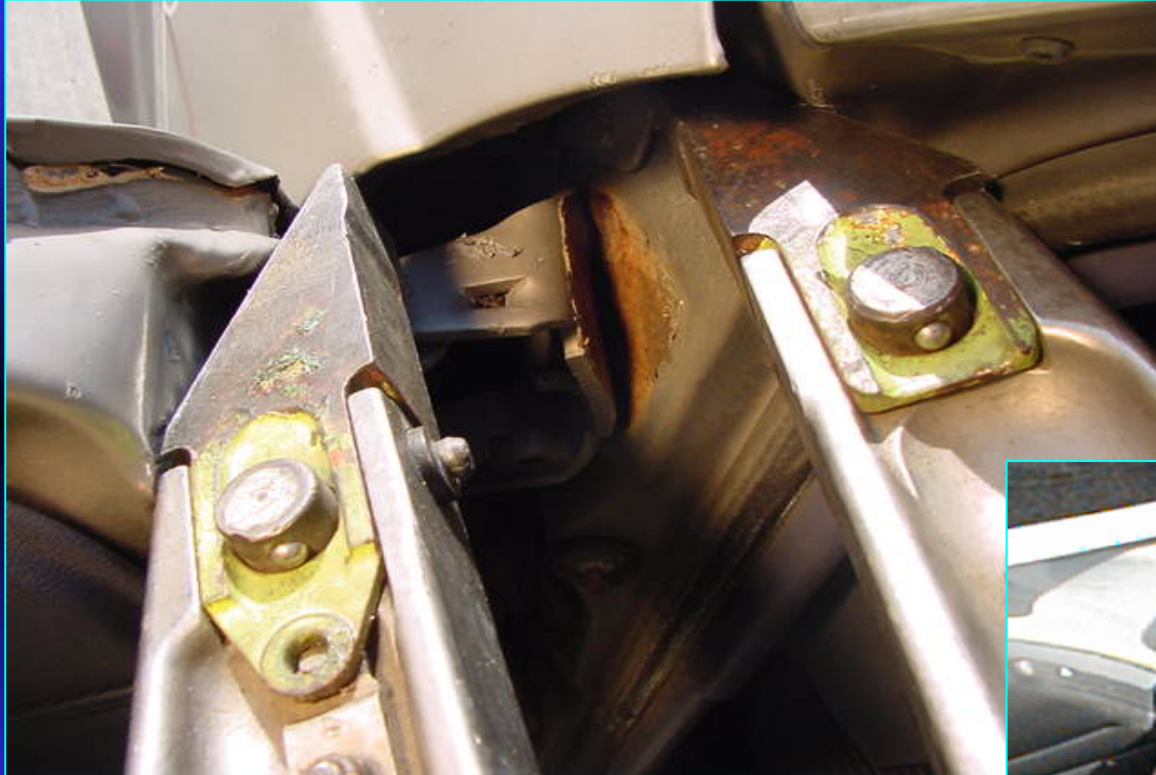



# Extrication Walk-thru

**Verdugo Fire Academy**

**Ch.25**

... more than fighting fires





# Extrication Walk-thru

**Verdugo Fire Academy**

**Ch.25**

... more than fighting fires





Tradition purchase point to “pop” a door...

# Extrication Walk-thru

**Verdugo Fire Academy**

**Ch.25**

... more than fighting fires





# Extrication Walk-thru

**Verdugo Fire Academy**

**Ch.25**

... more than fighting fires





# Extrication Walk-thru

**Verdugo Fire Academy**

**Ch.25**

... more than fighting fires





# Extrication Walk-thru

**Verdugo Fire Academy**

**Ch.25**

... more than fighting fires





# Extrication Walk-thru

**Verdugo Fire Academy**

**Ch.25**

... more than fighting fires





# Extrication Walk-thru



- Note: Due to new vehicle technology this techniques was abandoned in the mid 90's
- 1<sup>st</sup> Adjustable seat belt tensioners.
- 2<sup>nd</sup> air bags.

# Extrication Walk-thru

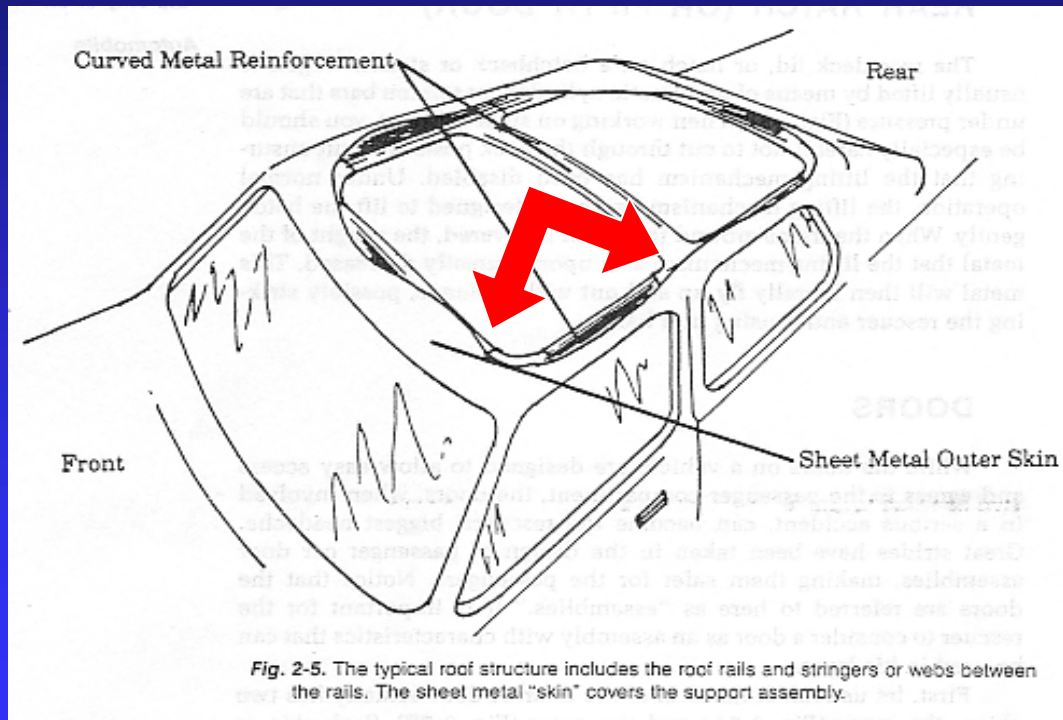

The technique adopted was making a **“V” Cut** as to not compromise the tool due to case hardened steel or the rescuer by exposing them to explosive, projectile and superheated gases from the air bag systems.



# Extrication Walk-thru

**Verdugo Fire Academy**

**Ch.25**

... more than fighting fires

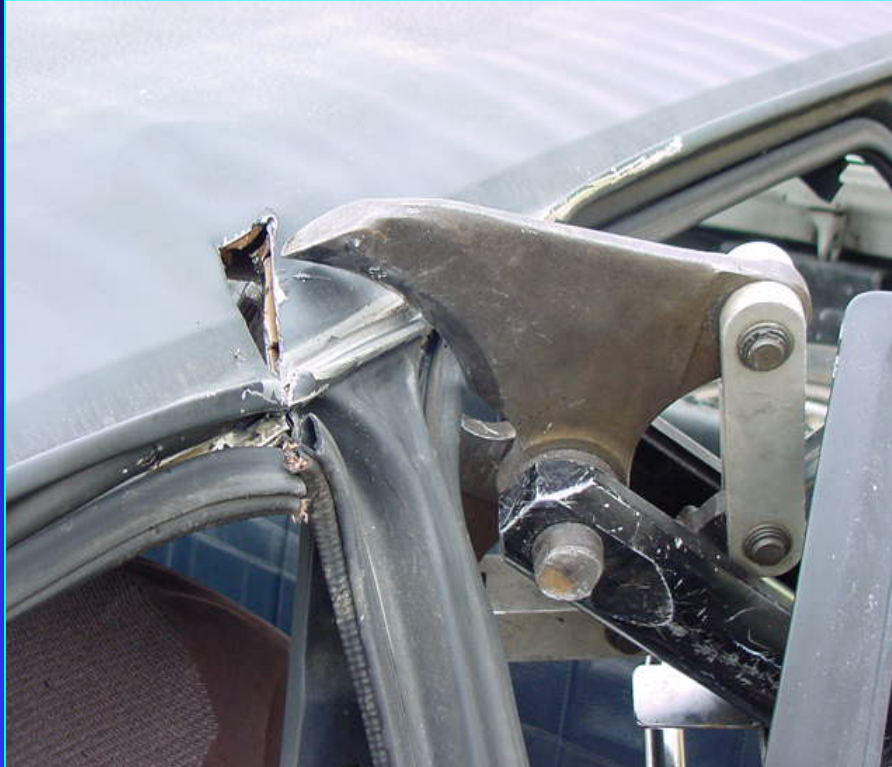

**“V” Cut**

# Extrication Walk-thru

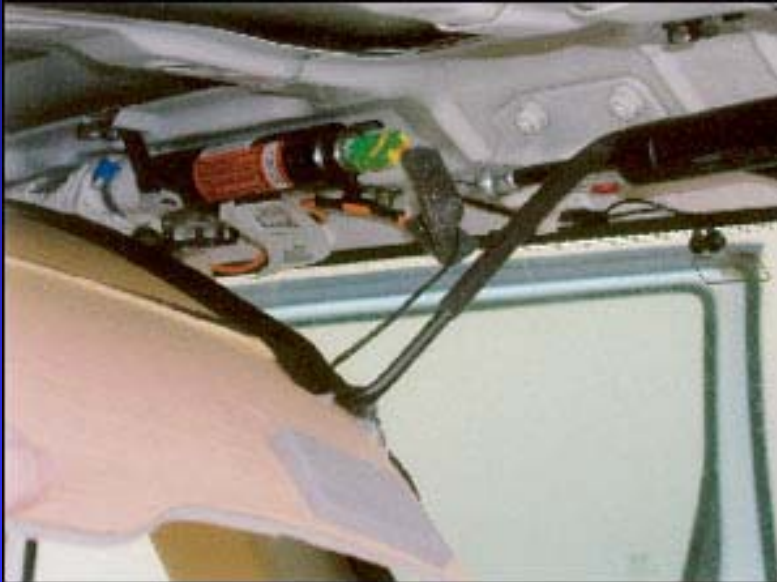

- In 2005 auto manufactures put compressed gas cylinders in the top of the “B” pillar forcing Extricators to return to the old way of doing thing.
- **REMEMBER: Strip and Peek before you cut.**



# Extrication Walk-thru

**Verdugo Fire Academy**

**Ch.25**

... more than fighting fires





# Extrication Walk-thru

**Verdugo Fire Academy**

**Ch.25**

... more than fighting fires





# Extrication Walk-thru

**Verdugo Fire Academy**

**Ch.25**

... more than fighting fires





# Extrication Walk-thru

**Verdugo Fire Academy**

**Ch.25**

... more than fighting fires





# Extrication Walk-thru

**Verdugo Fire Academy**

**Ch.25**

... more than fighting fires





# Extrication Walk-thru

**Verdugo Fire Academy**

**Ch.25**

... more than fighting fires





# Extrication Walk-thru

**Verdugo Fire Academy**

**Ch.25**

... more than fighting fires





# Extrication Walk-thru

**Verdugo Fire Academy**

**Ch.25**

... more than fighting fires





# Extrication Walk-thru

**Verdugo Fire Academy**

**Ch.25**

... more than fighting fires





# Extrication Walk-thru

**Verdugo Fire Academy**

**Ch.25**

... more than fighting fires





# Extrication Walk-thru

**Verdugo Fire Academy**

**Ch.25**

... more than fighting fires





# Extrication Walk-thru

**Verdugo Fire Academy**

**Ch.25**

... more than fighting fires





# Extrication Walk-thru

**Verdugo Fire Academy**

**Ch.25**

... more than fighting fires





# Extrication Walk-thru

**Verdugo Fire Academy**

**Ch.25**

... more than fighting fires





# Extrication Walk-thru

**Verdugo Fire Academy**

**Ch.25**

... more than fighting fires





## INTERIOR PARTS

# Other considerations

### ■ Dash assembly

- ◆ Is attached to the fire wall and may support the steering column.
- ◆ Because of airbag sensors and control modules the traditional dash push has been modified.



## INTERIOR PARTS

# Other considerations

- Compare:

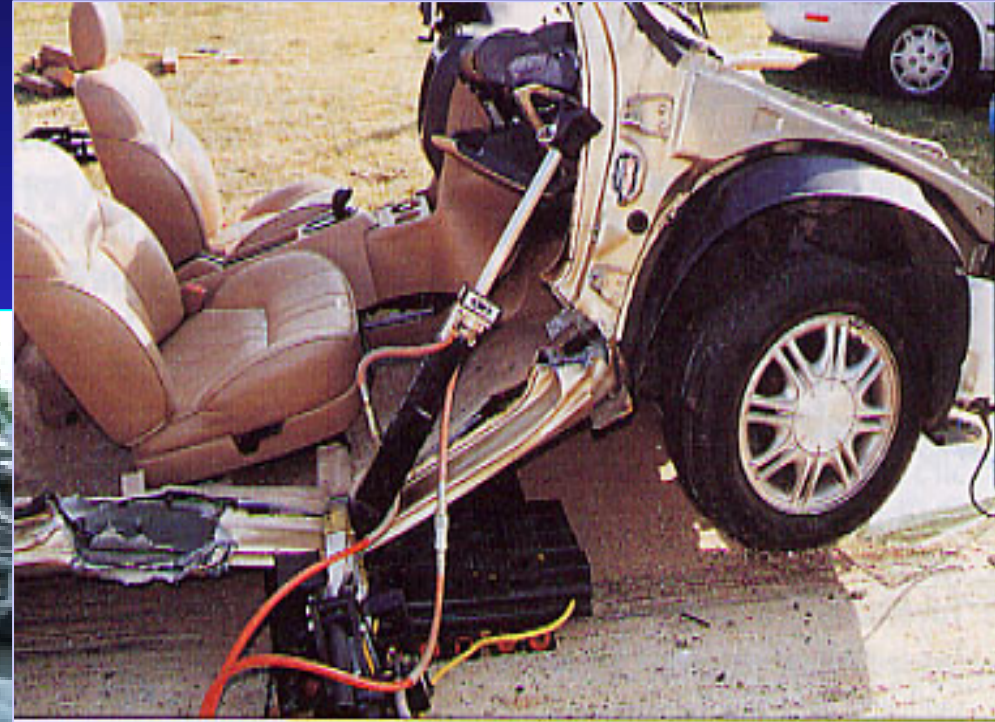



## INTERIOR PARTS

# Other considerations

### ■ Seats

- ◆ Front seats are attached to adjustable tracks and are operated manually or by power.
- ◆ Rear seats are on rigid frame and are usually not adjustable.
- ◆ Many rear seats fold down and may be a point of egress.



## INTERIOR PARTS

# Other considerations

### ■ Seat Belts

- ◆ Seat belts have tensioning device that are used in conjunction with the air bag system.
- ◆ It is an gas cylinder or explosive charge.

**ALWAYS CUT SEAT BELTS!**





## INTERIOR PARTS

# Other considerations

### ■ Pedals

- ◆ Operating pedals are usually steel of medium strength, attached to the under side of the fire wall by a pivot point.
- ◆ **Freeing the patient may involve cutting a shoe, displacing a pedal, or severing the pedal completely.**



# VEHICLE EXTRICATION

**Be on the winning team.**